

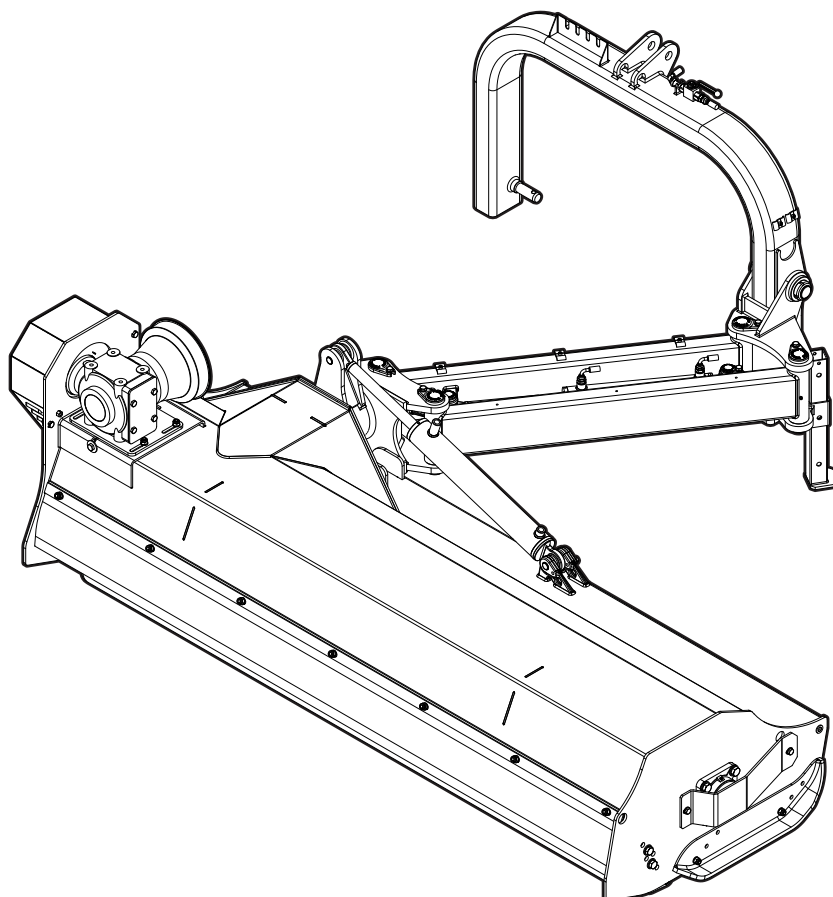

USE AND MAINTENANCE MANUAL

ZT-ZTE



SIDE SHREDDER

Model	Serial number
ZT2300	01
ZTE2300	01

EN-US

1	GENERAL INFORMATION	9
1.1	Scope and contents of the manual	9
1.1.1	Recipients	9
1.1.2	Updating the manual	9
1.1.3	Conservation	9
1.1.4	Copyright	9
1.2	Spare parts	10
1.3	Machine versions	11
2	SAFETY REGULATIONS	13
2.1	General safety rules	13
2.2	Safety regulations concerning road traffic	17
2.3	Safety rules during use	18
2.3.1	Responsibilities of the operator or owner	19
2.4	Safety regulations concerning the hydraulic system	20
2.5	Fire prevention	21
2.6	Safety gear and protection for the operator	22
2.6.1	Maintenance: safety rules	23
2.7	Working range of the machine	24
2.8	Safety decals	25
2.8.1	Replacing safety decals	29
2.8.2	Replacement of "ISO" decals with "ANSI" decals	30
3	TECHNICAL FEATURES	31
3.1	General description of the machine	31
3.1.1	Proper and improper use of the machine	31
3.2	Machine identification	32
3.3	Names of the parts	33
3.4	Technical data	34
3.5	Noise level	35
3.6	Working range	36
3.7	Variations	37
3.7.1	Flails	37
3.7.2	Controls with distributor	38
3.7.3	Runners (Optional)	39
4	INSTALLATION AND HANDLING	41
4.1	Hoisting	41
4.2	Removal of packing materials	42
4.3	Coupling to tractor	47
4.3.1	Attaching without a Quick Hitch	48
4.3.2	Attaching with a Quick Hitch	48
4.3.3	Hydraulic connections for lateral movement	49
4.4	Fitting the PTO shaft	50
4.5	Balancing the tractor	53
4.6	Disconnecting from the tractor	54
5	ADJUSTMENTS	55
5.1	Working speed adjustment	55
5.2	Adjusting the cutting height	56
5.3	Adjusting the belt tension	58
6	USE AND OPERATING RULES	61

6.1	Controls	61
6.2	Positioning the machine during work stages	62
6.3	Startup	63
6.3.1	Preliminary checks.....	63
6.3.2	Starting the machine.....	63
6.4	Work stages	64
6.5	Stopping	65
6.6	Transport position	66
7	ROUTINE MAINTENANCE	69
7.1	General information	69
7.2	Checklist	70
7.2.1	Every 8 working hours or every day.....	70
7.2.2	Every 50 working hours or once a month.....	71
7.2.3	Every 200 working hours.....	72
7.2.4	Every 500 working hours or once a month.....	73
7.3	Oil table	74
7.4	Greasing	75
7.5	Belt state	76
7.6	Hydraulic hose couplings	77
7.7	Bolt tightening	78
7.8	First use or resumption of use after prolonged disuse	80
7.9	Parking or storage	81
8	EXTRAORDINARY MAINTENANCE	83
8.1	Hose replacement	84
8.2	Belt replacement	85
8.3	Pulley replacement	87
8.4	Security pin replacement	88
8.5	Guards	89
8.5.1	Flaps.....	89
8.6	Rotor	90
8.7	Flails replacement	91
9	TROUBLESHOOTING TABLE	93
9.1	Troubleshooting table	93
9.1.1	General.....	93
10	DEMOLITION AND DISPOSAL	99
11	WARRANTY	101
11.1	Invalidation of the Warranty	101
12	OPTIONAL UNITS	103
12.1	Controls with distributor	104
12.1.1	Assembly procedure.....	104
12.2	Adjustable lateral runners	107

DECLARATION OF CONFORMITY

The **EC Declaration of Conformity**, provided together with the machine, is the document with which the Manufacturer certifies, on its own responsibility, that the machine complies with European Directives, Standards and Technical Specifications required (indicated in the Declaration) in order to conform to the basic requirements for sale and use in the European Union.

The Declaration of conformity must be considered an integral part of the machine and must always accompany the machine until it is scrapped.

If this document is not delivered together with the machine or gets lost, please request a copy from the Manufacturer.

Dichiarazione di conformità

	N° <input style="width: 100%;" type="text"/>																																																																																
Dichiarazione CE di Conformità Ai sensi della direttiva 2006/42/CE (che abroga la Direttiva 98/37/CE)																																																																																	
La ditta Sottoscritta FERRI s.r.l. dichiara sotto la propria responsabilità che la macchina																																																																																	
descrizione della macchina	codice n.serie (Testata / n.serie) Matricola																																																																																
è conforme ai Requisiti Essenziali di Sicurezza e di Tutela della Salute di cui alla Direttiva 2006/42/CE e alla compatibilità elettromagnetica per i modelli di macchine equipaggiate con dispositivi elettrici/elettronici di cui alla Direttiva 2004/108/CE. Per rispondere alle Conformità di cui alla direttiva sopra menzionata, sono state consultate le seguenti Norme Armonizzate: nonché le specifiche tecniche:																																																																																	
(Nome e qualifica del delegato dal fabbricante)																																																																																	
Firma del delegato																																																																																	
Persona autorizzata a costituire il Fascicolo Tecnico: Dott. Sandro Ferri																																																																																	
Tamara, (Luogo e data)																																																																																	
FERRI s.r.l. – Via Govoni, 30 – 44030 Tamara (Ferrara) – Italia - Tel. 0532 / 866 866 - Fax 0532 / 866 851																																																																																	
(tagliare lungo la linea tratteggiata)																																																																																	
Da compilare a cura del Rivenditore con i dati dell'Utilizzatore																																																																																	
COUPON DI GARANZIA																																																																																	
Serie Data Macchina Matricola Timbro del Rivenditore	<table border="1" style="width: 100%; border-collapse: collapse;"> <tr> <td style="width: 15%;"><input type="text"/></td> <td style="width: 15%;"><input type="text"/></td> <td style="width: 15%;"><input type="text"/></td> <td style="width: 15%;"><input type="text"/></td> <td style="width: 15%;"><input type="text"/></td> <td style="width: 15%;"><input type="text"/></td> <td style="width: 15%;"><input type="text"/></td> <td style="width: 15%;"><input type="text"/></td> </tr> <tr> <td colspan="2">Cognome</td> <td colspan="2">Nome</td> <td colspan="2">Data</td> <td colspan="2"></td> </tr> <tr> <td colspan="4">Ragione Sociale</td> <td colspan="4">Firma Utilizzatore</td> </tr> <tr> <td colspan="8">Indirizzo</td> </tr> <tr> <td colspan="2">Località</td> <td colspan="2">Stato/Prov</td> <td colspan="2">CAP</td> <td colspan="2"></td> </tr> <tr> <td colspan="4">Telefono</td> <td colspan="4">Fax</td> </tr> <tr> <td colspan="4">Timbro e Firma del Rivenditore</td> <td colspan="2">Matricola</td> <td colspan="2">Serie</td> </tr> <tr> <td colspan="4"></td> <td colspan="2">Modello</td> <td colspan="2"></td> </tr> <tr> <td colspan="8" style="font-size: x-small;"> Presa visione del Manuale Uso/Manutenzione, delle Norme di Sicurezza e delle Condizioni di Vendita/Garanzia. Autorizzazione al trattamento dei dati personali secondo quanto previsto dalla Legge (Dlgs 196/2003). </td> </tr> <tr> <td colspan="6"></td> <td colspan="2" style="text-align: right;"> Firma Utilizzatore (leggibile) </td> </tr> </table>	<input type="text"/>	<input type="text"/>	<input type="text"/>	<input type="text"/>	<input type="text"/>	<input type="text"/>	<input type="text"/>	<input type="text"/>	Cognome		Nome		Data				Ragione Sociale				Firma Utilizzatore				Indirizzo								Località		Stato/Prov		CAP				Telefono				Fax				Timbro e Firma del Rivenditore				Matricola		Serie						Modello				Presa visione del Manuale Uso/Manutenzione, delle Norme di Sicurezza e delle Condizioni di Vendita/Garanzia. Autorizzazione al trattamento dei dati personali secondo quanto previsto dalla Legge (Dlgs 196/2003).														Firma Utilizzatore (leggibile)	
<input type="text"/>	<input type="text"/>	<input type="text"/>	<input type="text"/>	<input type="text"/>	<input type="text"/>	<input type="text"/>	<input type="text"/>																																																																										
Cognome		Nome		Data																																																																													
Ragione Sociale				Firma Utilizzatore																																																																													
Indirizzo																																																																																	
Località		Stato/Prov		CAP																																																																													
Telefono				Fax																																																																													
Timbro e Firma del Rivenditore				Matricola		Serie																																																																											
				Modello																																																																													
Presa visione del Manuale Uso/Manutenzione, delle Norme di Sicurezza e delle Condizioni di Vendita/Garanzia. Autorizzazione al trattamento dei dati personali secondo quanto previsto dalla Legge (Dlgs 196/2003).																																																																																	
						Firma Utilizzatore (leggibile)																																																																											

The bottom part of the Declaration of conformity contains the **Warranty Coupon** which must be completed in full and returned to the Manufacturer in order for the rights under the warranty to be valid (see Chapter 11).

The machine described in this manual complies with:

European Directives

2006/42/EC	Machinery Directive
-------------------	---------------------

Harmonized standards

EN 4254-1	2009	Agricultural machinery - Safety - Part 1: General requirements
EN 13524	2009	Highway Maintenance Machines - Safety Requirements
EN ISO 13857	2008	Safety of machinery - Safety distances to prevent hazard zones being reached by upper and lower limbs
EN ISO 12100	2010	Safety of machinery - General principles for design - Risk assessment and risk reduction

Technical Specifications

ISO 11684	1995	Tractors, machinery for agriculture and forestry, powered lawn and garden equipment - Safety signs and hazard pictorials - General principles
EN ISO 3767-2	1998	Tractors, machinery for agriculture and forestry, powered lawn and garden equipment - Symbols for operator controls and other displays - Part 2: Symbols for agricultural tractors and machinery

PRELIMINARY STATEMENT

SAFETY RECOMMENDATIONS

The safety instructions contained in this manual are preceded by a warning symbol and message (CAUTION, WARNING and DANGER).

These precautions are meant to protect the personnel and safeguard those who work and/or are present in the working range of the machine.

Take the time to read all the instructions contained in the manual carefully.



THE WORD “CAUTION” REFERS TO SAFETY PRECAUTIONS DURING WORK AND MAINTENANCE THAT MUST BE TAKEN BY ALL PERSONS IN THE WORKING RANGE OF THE MACHINE TO PREVENT ACCIDENTS.



THE WORD “WARNING” INDICATES A POTENTIAL OR CONCEALED DANGER THAT COULD CAUSE INJURY OR DEATH. IT IS USED TO INVITE THE OPERATORS AND OTHER PERSONS TO TAKE APPROPRIATE MEASURES TO PREVENT POSSIBLE ACCIDENTS.



THE WORD “DANGER” INDICATES ANY FORBIDDEN ACTION THAT COULD CAUSE INJURY OR DEATH.

Prefazione

FAILURE TO COMPLY WITH THE INSTRUCTIONS, ESPECIALLY THOSE PRECEDED BY “CAUTION”, “WARNING” AND “DANGER” MAY RESULT IN SERIOUS DAMAGE, INJURY OR DEATH.

PREFACE

To work safely with the machine you must:

- 1) Comply with the general precautions for use of any mechanical equipment, described in Chapter 2;
- 2) Always follow the instructions for use provided in this manual.
- 3) In case of difficulty in installation, use or maintenance of the machine, contact specialized technical personnel (the Manufacturer, Dealers, Technical service personnel, etc.);
- 4) Do not remove, tamper with or alter any part of the machine unless foreseen by the manual;
- 5) Repair or replace any worn or broken parts and guards, following the instructions in the manual;
- 6) Keep the safety decals in good condition and perfectly legible;
- 7) Perform maintenance operations in accordance with the instructions in the manual;
- 8) Follow the safety regulations established by law;
- 9) Contact qualified, authorized, duly instructed and trained personnel.
- 10) Keep all the guards in perfect working condition.



WARNING

All the technical and preventive measures taken in the machine designed to protect against the launch of objects cannot ensure absolute safety. Even when used properly, it is still possible for small rocks, splinters or other objects to get through the protective guards and become airborne. It is absolutely fundamental to verify that **THERE IS NO ONE WITHIN THE WORKING RANGE OF THE MACHINE (AT LEAST 50 METERS/164'1" FT) WHEN IT IS IN OPERATION.** Pay particular attention when working near roads and/or buildings.



CAUTION

For machines equipped with electrical/hydraulic controls and/or heat exchangers, **IT IS ABSOLUTELY ESSENTIAL** to read the instructions for assembly of the electrical connections before connecting it to the tractor. Failure to comply with the instructions may cause damage to the electrical system and invalidate the warranty.

1 GENERAL INFORMATION

1.1 *Scope and contents of the manual*

This manual serves to provide the client with all the information necessary to use and manage the machine correctly, independently and safely. It contains information about safety devices, technical aspects, operation, maintenance and spare parts.

Read this manual carefully and follow the instructions scrupulously before making any use, inspection or other operations on the machine.

Correct use and regular maintenance will ensure proper operation and long life of the machine.

If you have any questions, contact the Manufacturer.



This manual has been prepared in accordance with the regulations in force at the time of printing.



The illustrations have a purely indicative value.
Some elements may not correspond exactly to those actually installed on the machine.

1.1.1 *Recipients*

This manual has been prepared for the operator and experts in charge of machine maintenance.

Operators must not perform actions restricted to qualified personnel.

The instructions contained in this manual are intended for an authorized, qualified expert who has been duly instructed and trained in the methods of driving the tractor to which the machine is connected.

1.1.2 *Updating the manual*

The information, descriptions and illustrations contained in this manual reflect the state of the art at the time of machine sale.

The Manufacturer, in its constant effort to improve its products and/or for market reasons, reserves the right to make changes to the machine at any time, for business or technical reasons, without notice and without giving the buyer the right to cancel the contract.

Any additions must be kept with the manual and considered an integral part thereof.

1.1.3 *Conservation*

The manual must be kept near the machine, protected against liquids and anything else that could jeopardize its legibility. The manual and Conformity Certificate are integral parts of the machine until it is disposed of. If the manual should be lost or become illegible, you should apply to the manufacturer for a copy.

1.1.4 *Copyright*

The copyright for this manual is the exclusive property of FERRI srl.

The texts, drawings and illustrations in this manual, or any part thereof, may not be disclosed or transmitted to third parties without the prior written authorization of FERRI srl.

1.2 Spare parts

We recommend that you use original "FERRI" replacements so as not to alter the technical features of the machine. If original parts are not used, FERRI has no liability for any damage to the machine, persons and/or property.



We recommend always using original spare parts and accessories. Using non-original parts invalidates the warranty as well as reducing the life and performance of the machine.

1.3 Machine versions

When working with the machine, the version differs depending on the direction of motion and position of the machine with respect to the tractor.

A	Direction of travel
1	Machine on the left
2	Machine on the right
3	Rear-end version
4	Front-end version
5	Reversed version

01-INFORMAZIONI GENERALI (Versione della macchina)

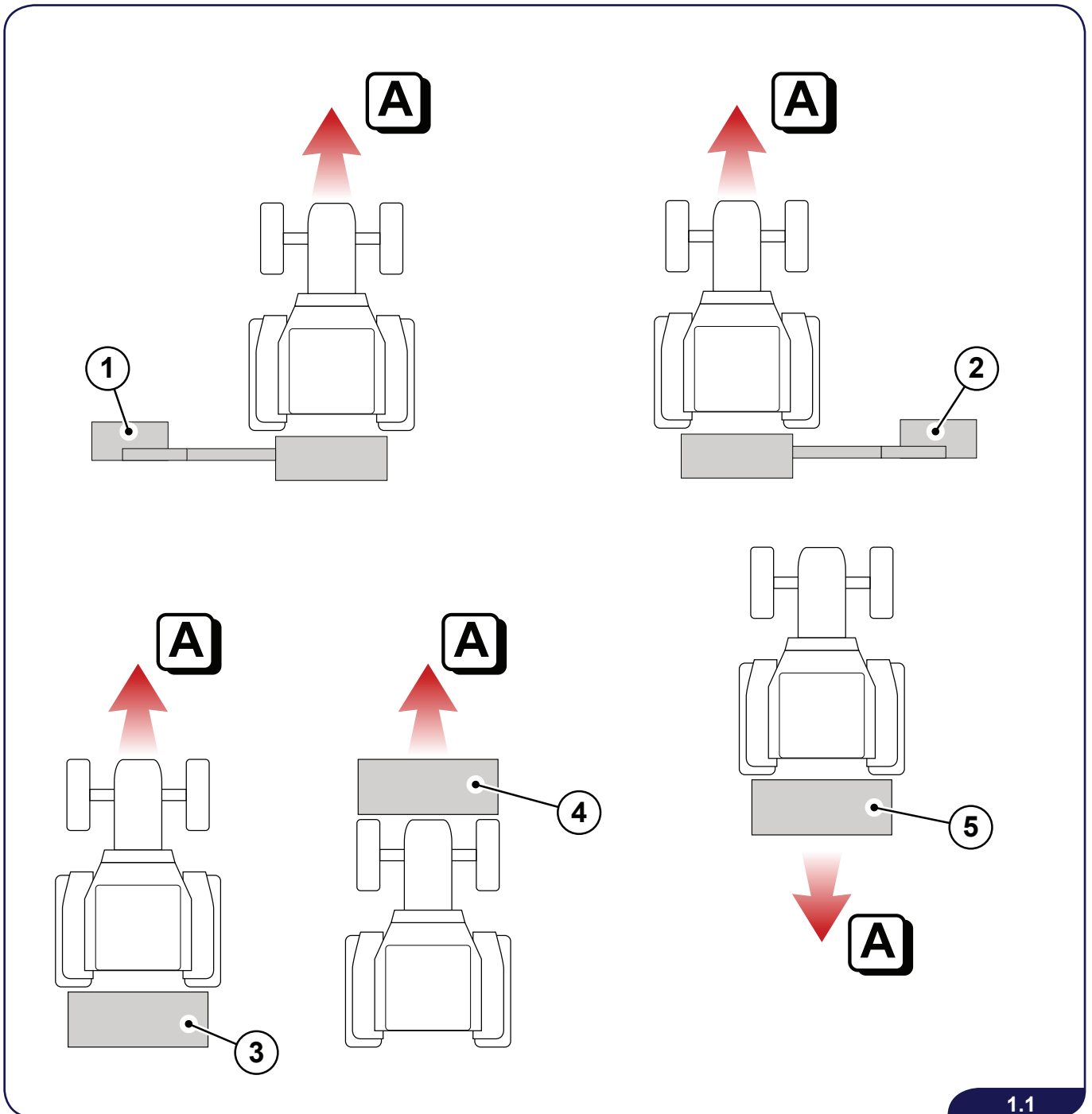

Page left blank intentionally

2 SAFETY REGULATIONS

2.1 General safety rules

The machine was designed and built according to adequate safety standards. Before using the machine, take all the recommended precautions and follow all the instructions in the manual to prevent accidents.

- ▶ Make sure there are no rocks or large objects, tree stumps or metallic objects of any kind (nets, wires, cables, chains, pipes, etc.) on the ground.
- ▶ Carefully follow the instructions to adjust the height of the machine off the ground.
- ▶ When working with the machine, make sure there is no one in a radius of at least 164 feet.
- ▶ Never work close to the ground on wet terrain. Under these conditions, excessive power is required of the engine, and the filling of the protective hood on the rotor with compressed mud causes excess wear on the flails and drive belts, endangering the performance and balancing of the machine.
- ▶ A tractor of suitable power must be used for every machine. If you use a tractor with higher power than the maximum the machine can absorb, install a PTO with clutch (torque limiter) so as not to damage the drive unit and flail holder shaft.
- ▶ Examine the safety decals on the machine and described in this manual. To work safely, keep them clean and, if illegible, replace them with new ones.



FERRI is not responsible for damages caused by improper use of the machine.



Always inspect the machine thoroughly before use.



Before starting to use the machine or performing maintenance, read the instructions and safety warnings in the manual and on the machine carefully. Take care to comply with all the accident-prevention and safety regulations.



Do not use the machine to lift people, animals or objects.

- ▶ Before using the machine, you must understand how all the devices, controls and functions work.
- ▶ Make sure all the safety devices are in good condition and properly positioned. In case of breakage or damage, replace them at once.
- ▶ Before getting off the tractor and before performing any maintenance, apply the parking brake, stop the engine and remove the ignition key from the dashboard.
- ▶ The user is responsible for machine maintenance.

- ▶ The owner is responsible for providing all the instructions to operators or employees before using the machine in compliance with the regulations in the destination country.
- ▶ Only an operator properly trained and instructed in the safety regulations can operate the machine.



DANGER

DO NOT USE the machine if there are any persons and/or animals in the range of action of the machine.



DANGER

**Start the tractor only when properly seated.
Read the instructions for starting the machine, furnished in the user manual.**

- ▶ Always keep the manual at hand for rapid consultation. If it is lost or damaged, request a replacement copy from the Manufacturer.
- ▶ Disconnect the PTO on the tractor (or vehicle) before starting the machine motor.
- ▶ The machine is designed to be used by one operator only.
- ▶ Do not work if you are unwell or are under the influence of alcohol, drugs or medicines.
- ▶ Keep the machine clean and free of extraneous material (debris, tools, other objects) that could cause damage to the operator and to the machine.



WARNING

Always wear the seat belts. Falls or overturning of the machine can cause serious injury or death.



DANGER

This machine has been designed for use only with closed-cab motor vehicles and/or tractors!

If the tractor has an open cab you must:

- 1) provide adequate personal protective equipment for the operator;**
- 2) provide protection against the possible launch of objects;**
- 3) use a safety structure to prevent the tractor from overturning (Roll Over Protective Structure - ROPS).**

- ▶ Prolonged operations can cause physical and mental fatigue. Do not use the machine and tractor if you are not in good psycho-physical condition.



DANGER

It is strictly forbidden to climb or hitch a ride on the machine when it is moving.

- ▶ Make sure the PTO shaft is correctly fitted after each operation to connect the machine.
- ▶ Disconnect the machine from the tractor only on compact level ground, ensuring that it is stopped and stable.



DANGER

**Make sure the guards on the PTO drive shaft are intact and in good condition.
When the machine is not connected to the power unit, hang the hydraulic hoses on their supports.**

- ▶ In case of breakage or deterioration of the PTO shaft guards, replace them immediately.
- ▶ Do not use the control levers or hoses as supports. These parts are movable and do not ensure your stability.
- ▶ Never work, walk or stand under the raised boom. To prevent accidental falls, do not perform maintenance under the raised boom unless it is suitably supported.
- ▶ Never use the boom to lift people or objects.



Do not get between the tractor (or vehicle) and the machine for any reason, with the engine running and the power take off engaged.



Avoid touching hot surfaces like:

- 1) Oil tank;
- 2) Pumps;
- 3) Motors;
- 4) Valves;
- 5) Gearbox;
- 6) Hydraulic hose couplings.

To prevent burns, wear gloves and safety goggles when performing maintenance on hot surfaces.

Use the machine preferably during the day.

In conditions of reduced visibility, the tractor lighting system must be used.

If the machine is used at night:

- 1) Provide a backup lighting system to ensure good visibility in the whole work area at all times;
- 2) Do not create dangerous reflections for the operator;
- 3) Provide sufficient illumination in the cab so that the operator can see the controls well.



Work only in places that are well-lighted with natural or artificial lighting. The operator's visibility when working must be at least 320 feet.



Avoid contact with guard-rails or concrete structures to prevent damaging the flails.



Replace any bent or broken flails with new ones. Do not straighten or weld flails so as not to alter their strength and jeopardize safety.



Carefully inspect the work area and remove any debris or extraneous material to prevent damage to the machine, persons and/or property. Any objects that cannot be removed must be clearly marked and avoided by the operator. Stop cutting immediately if flails strike a foreign object.



Do not run the tractor engine in enclosed places lacking ventilation. The exhaust fumes can be hazardous to health.



MAKE SURE THE FLAILS HAVE STOPPED COMPLETELY BEFORE APPROACHING THE MACHINE.



Before leaving the driver's seat and before performing any maintenance, always apply the parking brake and disengage the PTO. Stop the engine and remove the ignition key from the dashboard; wait until all moving parts have come to a complete stop.



Never let children or other people climb on or operate the tractor or the equipment. Possible falls could cause serious injury or death.



The user may perform only the maintenance operations described in this manual.



Make sure to perform all maintenance operations (routine and extraordinary) on the tractor (or vehicle) to which the machine will be connected.

- ▶ Do not tamper with or modify the equipment in any way. Unauthorized alterations may impair the function and/or safety of the machine and could affect the life of the equipment. In such case, the user will be the only party responsible for any damages or injury.



Do not tamper with, remove or bypass the guards and/or safety devices on the machine.

- ▶ Use only original "FERRI" spare parts.

FERRI is not responsible in case of:

- ▶ Improper use of the machine or use by untrained personnel;
- ▶ Serious neglect of required maintenance;
- ▶ Unauthorized alterations or repairs;
- ▶ Use of non-original spare parts or parts not specifically intended for this model;
- ▶ Total or partial failure to follow the instructions;
- ▶ Failure to observe the common rules for safety at work.

2.2 Safety regulations concerning road traffic



If it should be necessary to drive on a public road, obey the highway code scrupulously. Use particular care to control the vehicle's speed.

Observe the following rules when using public roads with the machine coupled to the tractor (or vehicle):

- ▶ Make sure that all the lights and reflectors are working, clean, properly positioned and clearly visible as required by local regulations.
- ▶ Before driving on the road, consider installing optional light bars.
- ▶ When driving on public roads, observe all road regulations.
- ▶ Clean the tires of the tractor (or other vehicle) to eliminate any traces of mud before entering public roads from muddy or unpaved terrain.



Check that the steering and brakes of the tractor (or vehicle) are in good condition and operate properly.

- ▶ Disengage the tractor PTO.
- ▶ Never transport the machine with the moving flail holder shaft, even for short distances. Make sure that the rotor control is disengaged and the moving parts of the machine have all come to a complete stop.
- ▶ Lock the machine with the safety devices provided.
- ▶ In case of use for road maintenance:
 - 1) The machine must be operated only by specially trained personnel instructed in its safe use;
 - 2) The safety procedures imposed by the appropriate organization must be implemented;
 - 3) Follow the machine with a vehicle, about 20-30 meters (65' 7" - 98' 5" ft) behind it, to signal the potential danger to the other vehicles on the road;
 - 4) Have the machine preceded by appropriate signals to enable vehicles approaching from the opposite direction to stay a safe distance away from the working area of the machine;
- ▶ Do not allow anyone to ride on the tractor (or vehicle), or on the machine during transport.
- ▶ Reduce speed on rough roads and surfaces.
- ▶ Use rotating flashing lights on the tractor (or vehicle) during the transport phase unless they are prohibited by local safety regulations.
- ▶ Make sure that the machine has been correctly hitched to the tractor (or vehicle) and that all the safety pins have been mounted correctly.
- ▶ Use the hoist on the tractor to raise the machine hitched to the 3-point coupling to the maximum height above ground.
- ▶ Test the tractor (or vehicle) at low speed and increase it gradually. Gently test the brakes to determine the braking characteristics of the tractor (or vehicle) with the machine hitched.



Always proceed at a moderate speed, especially on rough surfaces and steep slopes, to avoid tipping over. The weight of the machine alters the stability of the tractor (or other vehicle) and influences its behavior on the road, as well as its steering and braking capacity. Check the hoisting capacity and stability of the tractor (or other vehicle) to prevent overturning and/or loss of grip by the turning wheels.

02-Norme per la circolazione stradale

2.3 Safety rules during use



Always check the machine carefully before starting it up, and particularly, verify the good working order of accident prevention equipment.



Many objects such as cables, ropes, wires, rocks, chains or debris may fly into the air at high speed following an impact with the flails.
Inspect the work area and remove any potentially hazardous objects.

- ▶ When working, take care to avoid any contact with hard objects like: manhole covers, sumps, rocks, guard rails, tracks. Contact could cause breakage of the flails and launch them at very high speed.
- ▶ If any steel wire, ropes, chains or other should tangle itself around the rotor, disconnect the rotor control and all the other controls. Switch off the engine on the tractor (or vehicle). Apply the parking brake. Remove the ignition key from the dashboard of the tractor (or vehicle). Wait until all the moving parts come to a stop, to prevent damage or dangerous situations. **Wear work gloves and use pliers or shears to remove the tangled object. Do not attempt to disentangle it by reversing the rotor movement.**
- ▶ **Do not continue to use the machine if there are unusual or excessive vibrations, as this could cause breakages and/or serious damage. Inspect the machine to find the cause of the vibration and eliminate it before resuming use. If the problem persists, contact an authorized workshop without delay.**
- ▶ Do not allow the flail rotor to spin when the machine is raised off the ground.
- ▶ Do not work with the boom extended on sloping terrain. Always check the stability of the tractor (or vehicle). Check stability from a safe position, holding the flail head horizontal and as close as possible to the ground. Then extend the boom slowly.
- ▶ Before using the hydraulic controls for the movements of the machine, make sure no persons, animals or objects are within the working radius of the machine.
- ▶ It is strictly forbidden to keep the rotor spinning while raising or lowering the shredder head.
- ▶ Read and make sure you understand the user manual and all the warning signs before operating, servicing, repairing and/or replacing parts.
- ▶ Never let anyone climb on the tractor (or vehicle) and/or on the equipment.
- ▶ Check all the guards and protective barriers. If damaged, repair and/or replace them before using the equipment.
- ▶ Keep your hands, feet, hair and clothing away from all moving parts.
- ▶ Switch off all the controls and stop the engine. Apply the parking brake and remove the ignition key from the dashboard of the tractor (or vehicle). Wait for all moving parts to come to a complete stop before performing any maintenance and repairs or replacing any parts.
- ▶ Before using the equipment, make sure there are no children or other persons in the danger zone around the machine. If necessary, stop all the moving parts of the machine.
- ▶ Keep all hydraulic lines, couplings and hitches tightly fastened. Check for possible oil leaks.
- ▶ Keep the lights, reflectors and rear-view mirrors on the tractor (or vehicle) clean and in good working order.
- ▶ Use the rotating beacon on the tractor (or vehicle) whenever the machine is running or during transport.
- ▶ Never place your hands or feet under the machine or near any moving parts while it is working or the tractor (or vehicle) engine is running.
- ▶ Objects can be thrown out with sufficient force to severely injure people within the working range of the machine (at least 164 feet). Make sure no one is near the machine when it is in motion.
- ▶ Inspect the work area to make sure there are no hidden obstacles.
- ▶ Do not stop or start suddenly when going up or down a hill.
- ▶ Review all the safety instructions with all operators at least once a year.
- ▶ Never leave driver's seat while the machine is in the raised position. Lower the machine to the ground, disengage the PTO and switch off the tractor (or vehicle) engine before leaving the driver's seat.
- ▶ Never leave the machine unsupervised while the tractor (or vehicle) is moving.



Safe operating speed depends on terrain condition and on the type, density and height of the material to be cut.



Use slow operating speeds when cutting on steep slopes, in the presence of overhead constructions or ditches, and when debris or objects on the ground have to be avoided.



When extending the telescopic boom, hold the flail head close to the ground at all times, to ensure the machine is transversally stable regardless of the work conditions and characteristics of the ground.



Absolutely avoid opening the boom horizontally above slopes, canals, ditches or similar.

2.3.1 Responsibilities of the operator or owner

02-Norme di sicurezza durante l'uso

The owner or operator is responsible for reading the manual and teaching all users before they begin to work with this machine. In addition to the design and specific configuration of the machine, risk analysis and accident prevention depend on prudence, attention and good sense of the personnel involved in the work, transport, maintenance and storage of the equipment and in its use and maintenance in service.

Follow all instructions to the letter. Safety is in everyone's interest. Follow all the recommended safety procedures as they will ensure that the work is done safely with regard to the operators and other personnel in the machine work area. Operators who have not taken a training course are not qualified to use the machine.

2.4 Safety regulations concerning the hydraulic system



Any maintenance on the hydraulic system must be performed by specially trained personnel.

- ▶ Replace any damaged or worn hydraulic hoses and any bent or dented metal pipes.
- ▶ Do not try to repair the hydraulic system, couplings or hoses using tape, clamps or other. The hydraulic system operates under high-pressure. Unskilled repairs could be dangerous.
- ▶ Before applying pressure to the system, make sure all components are tightly fastened and all lines, hoses and couplings are in good condition.
- ▶ Stop immediately in case of oil leaks.
- ▶ **IMPORTANT: Never search for leaks with your bare hands. Always wear suitable work gloves.**
- ▶ Oil under high pressure may penetrate the skin causing serious infections or allergies. In this case contact a doctor immediately.
- ▶ Check the hydraulic hoses for wear. In case of deterioration (or at least every 6 years) replace them.
- ▶ Before working on the hydraulic system, lower the end tool, discharge all pressure and switch off the tractor engine.
- ▶ Dispose of used oil and grease in accordance with the laws on pollution.
- ▶ On tractors equipped with hydraulic system, the system pressure must not exceed 190 bar.
- ▶ When the machine is not connected to the power unit, hang the hydraulic hoses on their supports.

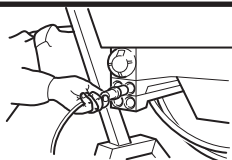

Make sure the hydraulic hoses are correctly fastened and installed. Their reversal causes movements that are the opposite of those required.



Make sure that there is no pressure inside the hydraulic system before performing maintenance or repair operations. If there is pressure, open and close the hydraulic controls several times to discharge the pressure in the system.

2.5 Fire prevention

- ▶ Keep a fire extinguisher of adequate capacity on the vehicle and recharge it periodically. The use of hand extinguishers is restricted to trained personnel.
- ▶ The personnel assigned to the vehicle must be instructed about what to do in case of fire.
- ▶ All fuels, and most lubricants and hydraulic fluids are flammable.
- ▶ Switch off the engine before filling the tank with fuel.
- ▶ Do not smoke while filling the tank with fuel or topping up hydraulic fluid levels.
- ▶ Do not fill the fuel tank near open flames or in enclosed places.
- ▶ Never siphon fuel.
- ▶ Before starting the engine, make sure that there are no leaks or residues of fuel, lubricants, or other fluids that could cause a fire.
- ▶ Short-circuits can cause fires. Check the conditions of the terminals to the batteries, cables, and electrical appliances periodically.
- ▶ Never store flammable substances in places inappropriate for the purpose.
- ▶ Do not puncture or burn pressurized containers or canisters.
- ▶ Never accumulate materials soaked with flammable substances.
- ▶ In order to reduce the risk of combustion to a minimum, clean the machine regularly using the appropriate equipment (compressed air or water spray cleaners).



DANGER

When cleaning the machine, never spray water directly onto the electric boxes.

- ▶ Use the appropriate fire extinguishing methods (carbon dioxide, foam, chemical powder).
- ▶ Use water spray only to cool surfaces exposed to fire.
- ▶ To clean mechanical parts, never use gasoline, solvents or other flammable and/or toxic fluids. Use approved, non-flammable and non-toxic solvents available on the market.
- ▶ Never weld near tanks, hoses, drums, electrical cables or flammable materials in general.

2.6 Safety gear and protection for the operator

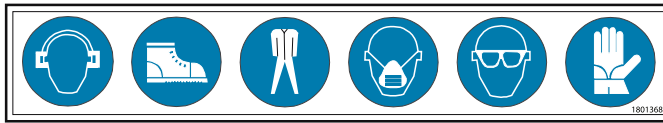

Wear safety footwear, overalls, safety gloves and, if necessary, earplugs and a face mask during maintenance, repair, movement or storage of the machine.

We recommend that the operator is fully protected against the projection of splinters, stones or other materials, when the machine is used in places where there could be stones or similar. Fit a 10 mm thick single pane (in plexiglass or polycarbonate) to the driver's cab - on the work side (1) or on the rear or front side (2) to prevent the bodies expelled by the end tool from:

- ▶ Breaking the cab windows.
- ▶ Injuring the operator.

Mount the machine only on tractors with approved anti-roll over driving cab (ROPS).

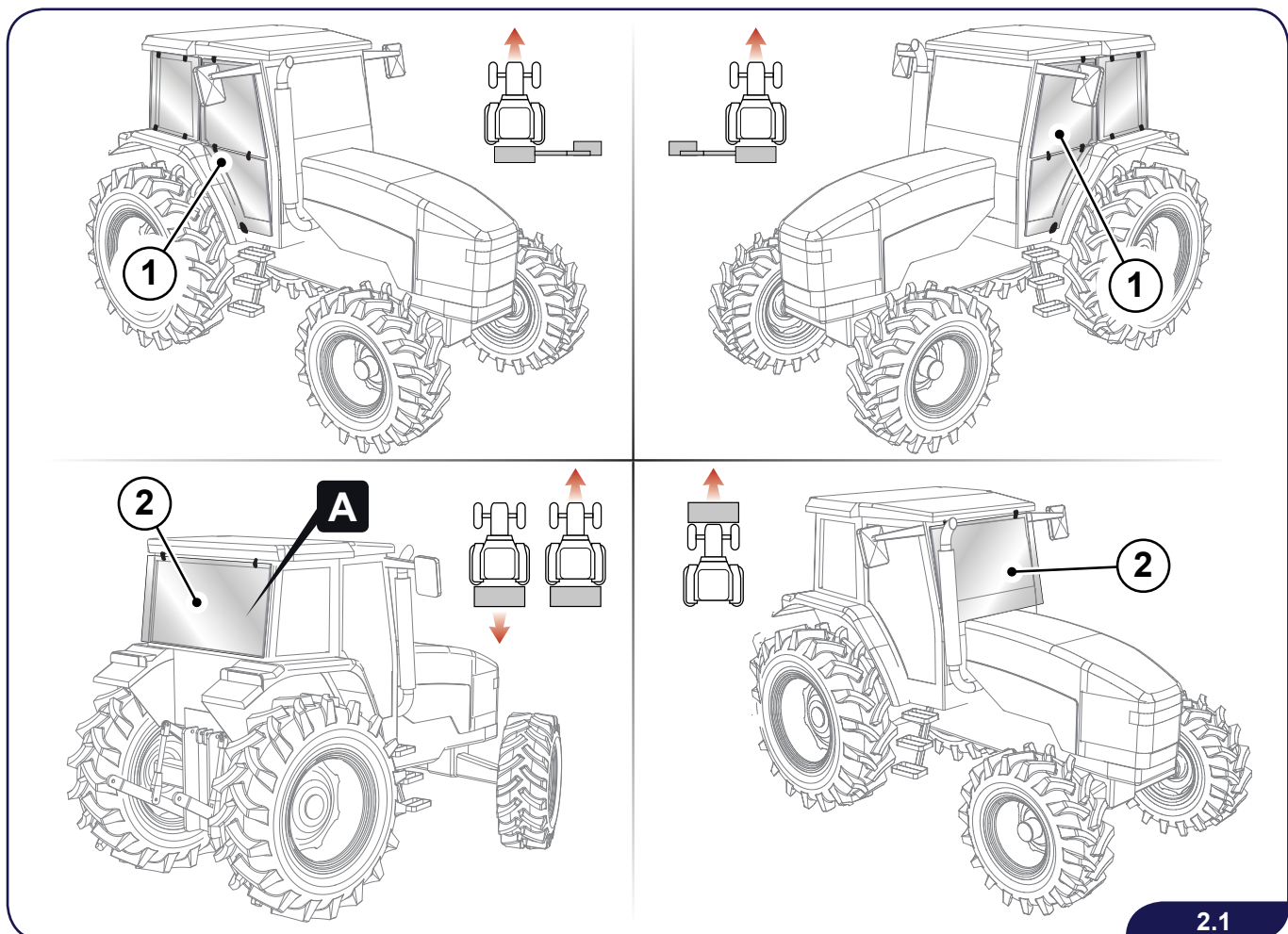

2.1



ONLY IN CASE OF VENTRAL MACHINES:
 due to the presence of the booms on one side of the tractor, the back door (A) is to be considered an emergency exit.

2.6.1 Maintenance: safety rules

- ▶ When the operator leaves the driver's seat on the tractor (or other motor vehicle) he must:
 - 1) Lower the shredder body to a horizontal plane. Position the standing feet (if any) and set the machine on the ground using the hoist on the tractor (vehicle);
 - 2) Disconnect the mechanical, hydraulic and electric power of the machine;
 - 3) Set the parking brake on the tractor (vehicle);
 - 4) Stop the engine on the tractor (vehicle) and remove the key.



Do not work underneath the machine or elevated parts of the machine if not correctly supported, to prevent sudden or accidental falls that could cause the serious injury or death.

- ▶ Keep the work area clean and dry.
- ▶ Make sure all electrical outlets and tools are properly grounded.
- ▶ Use an auxiliary light while performing maintenance jobs.
- ▶ Use only tools, wrenches and hoists of sufficient capacity for the job.
- ▶ Never work on the chassis, rotor or under the machine unless the tractor engine is off and the PTO disconnected.
- ▶ After completing any maintenance job, make sure that all the guards have been positioned correctly and are in good condition.
- ▶ Maintenance personnel should not wear loose clothing or accessories that could become entangled in the mechanisms (sleeves without closed cuffs, belts, chains, bracelets, rings).
- ▶ Check the pressure of the hydraulic circuit before servicing or disconnecting the machine from the tractor.
- ▶ Make sure the terminal equipment is resting correctly on the ground.
- ▶ Discharge any residual pressure in the system.
- ▶ Disconnect the electric wires from the tractor (vehicle) battery when performing any welding operations. Disconnect the electric system of the tractor (vehicle) if welding operations are performed with the machine installed on the tractor.
- ▶ Before applying pressure to the hydraulic system, make sure all lines, joints and fittings are tight and in good condition.
- ▶ Inspect all moving parts periodically to check for wear. If necessary, replace with original spare parts.
- ▶ Do not weld or attempt to repair welds on parts subject to movement, to prevent vibrations that could endanger the machine and its safety.



Use a ladder or elevated platform to access high points which cannot be reached from the ground. Slipping and falling can cause serious injury or death. Do not lean the ladder against the machine.

2.7 Working range of the machine

- ▶ Objects can be thrown out with sufficient force to severely injure people within the working range of the machine (at least 50 m/164'1" ft). Make sure no one is near the machine when it is in motion.
- ▶ Stay out of the working range of the machine.
- ▶ Always know where all additional personnel are located when operating the machine. Never allow anyone within the hazard area.

2.8 Safety decals

- ▶ Keep safety decals clean and legible at all times.
- ▶ Replace any missing or illegible decals.
- ▶ Whenever you replace parts of the machine on which a safety decal is mounted, remember to replace the decal on the new part.
- ▶ Safety decals can be ordered from your local Dealer or directly from the Manufacturer.



**Make sure the safety decals are legible.
Clean them with a cloth, soap and water.
Replace damaged safety decals with others of the same type; make sure to apply them in their original positions.**

02-Pittogrammi di sicurezza

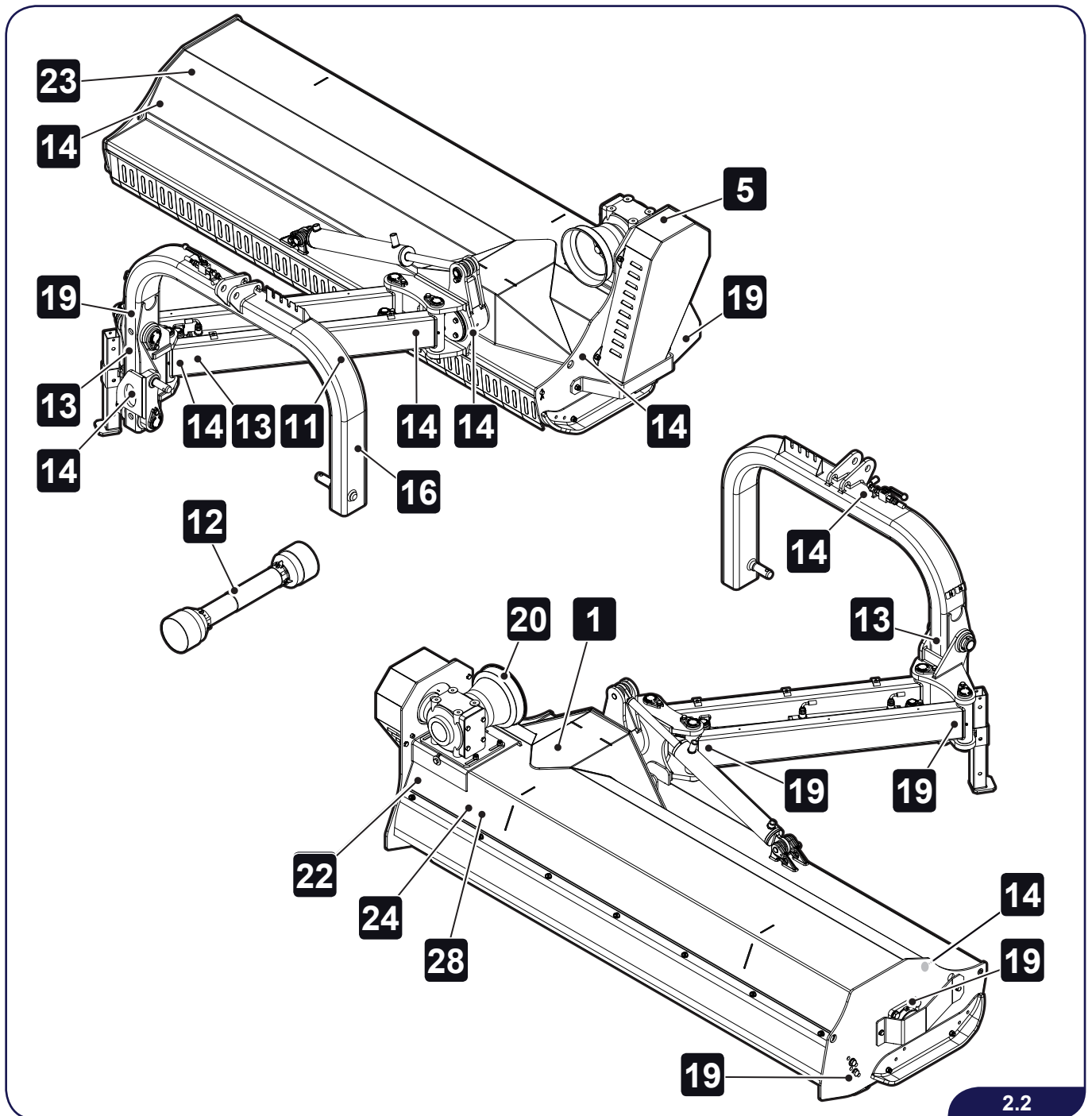











2.2









DESCRIPTION OF DECALS	
1	<p>Adjustments and maintenance must be carried out after reading the manual for use and maintenance, with the machine stopped and the key removed.</p>
2	<p>Check the direction of rotation and the number of revolutions (540 rpm) of the tractor PTO before engaging the PTO shaft.</p>
3	<p>Check the direction of rotation and the number of revolutions (1000 rpm) of the tractor PTO before engaging the PTO shaft.</p>
4	<p>Danger of flying objects. Keep at a distance of at least 50 meters (164' 1" ft) from the machine.</p>
5	<p>Do not remove or open the protective casings until the belts have come to a complete stop.</p>
6	<p>Do not climb or ride on the machine.</p>
7	<p>Danger of crushing the lower limbs. Keep safety distances.</p>
8	<p>Take care when working near overhead electricity lines.</p>
9	<p>Danger of injury to the limbs, DO NOT APPROACH THE MACHINE IN ACTION. If any extraneous material (metal wires, ropes, etc.) become twisted around the rotor, stop the machine immediately.</p>
10	<p>Make sure the rotor shaft and the other parts of the machine are completely stopped before approaching.</p>

02-Tabella Pittogrammi (ISO)

DESCRIPTION OF DECALS

<p>11</p>		<p>Use the required Personal Protection Equipment.</p>
<p>12</p>		<p>Keep at a safe distance from PTO. Do not perform any maintenance and/or control work when the power take off is engaged.</p>
<p>13</p>		<p>Risk of crushing and cutting the hands. Do not place your hands near any moving parts of the machine.</p>
<p>14</p>		<p>Fastening point for hoisting the machine. To hoist the machine, fasten hooks to the machine exclusively in the points indicated.</p>
<p>15</p>		<p>Risk of falling of lifted parts of the machine. Do not stand under the machine or in its vicinity when it is working.</p>
<p>16</p>		<p>Do not get between the tractor and the machine for any reason, with the engine running and the power take-off engaged.</p>
<p>17</p>		<p>Make sure the flails and the other parts of the machine are completely stopped before approaching.</p>
<p>18</p>		<p>To handle the machine with a forklift truck, use only the points indicated.</p>
<p>19</p>		<p>Grease points. Perform routine maintenance every 8 hours of work (see Chapter 7).</p>
<p>20</p>		<p>Indicates the direction of rotation and the number of revolutions (540 rpm) of the tractor power take-off.</p>

02-Tabella Pittogrammi (ISO)

DESCRIPTION OF DECALS	
21	 <p>Indicates the direction of rotation and the number of revolutions (1000 rpm) of the tractor power take-off.</p>
22	 <p>Decal grouping several of the warnings described above.</p>
23	 <p>Decal grouping several of the warnings described above.</p>
24	 <p>The machine has been designed for use by one operator only. Never let children or other people climb on or operate the tractor or the machine.</p>
25	 <p>Risk of burns. Keep a safe distance from all hot surfaces.</p>
26	 <p>Decal grouping several of the warnings described above.</p>
27	 <p>Decal grouping several of the warnings described above.</p>
28	 <p>Keep at a safe distance from the working range of the machine.</p>
29	 <p>Decal grouping several of the warnings described above.</p>

02-Tabella Pittogrammi (ISO)

2.8.1 Replacing safety decals

- ▶ Make sure the application zone is clean and dry.
- ▶ Decide the exact position before you remove the protective paper off the decal.
- ▶ Remove a small portion of the protective adhesive paper.
- ▶ Align the decal over the specified area and carefully press the small exposed adhesive part.
- ▶ Remove the rest of the protective paper from the adhesive and carefully press all over the decal so that it adheres to the surface completely.
- ▶ Any small air bubbles trapped inside the adhesive can be eliminated by pricking the paper with a pin and smoothing the paper detached from the adhesive.

2.8.2 Replacement of "ISO" decals with "ANSI" decals

If the machine is sold in countries outside the European Community, where the reference standard in force is ANSI Z535.4, make sure, when delivering the machine, that the decals required by that standard have been applied. If necessary, replace the ISO decals (yellow background) with the ANSI decals, the Manufacturer furnishes a kit (1) of replacements to apply (by the Distributor or on the Client's premises) as shown in the figure.

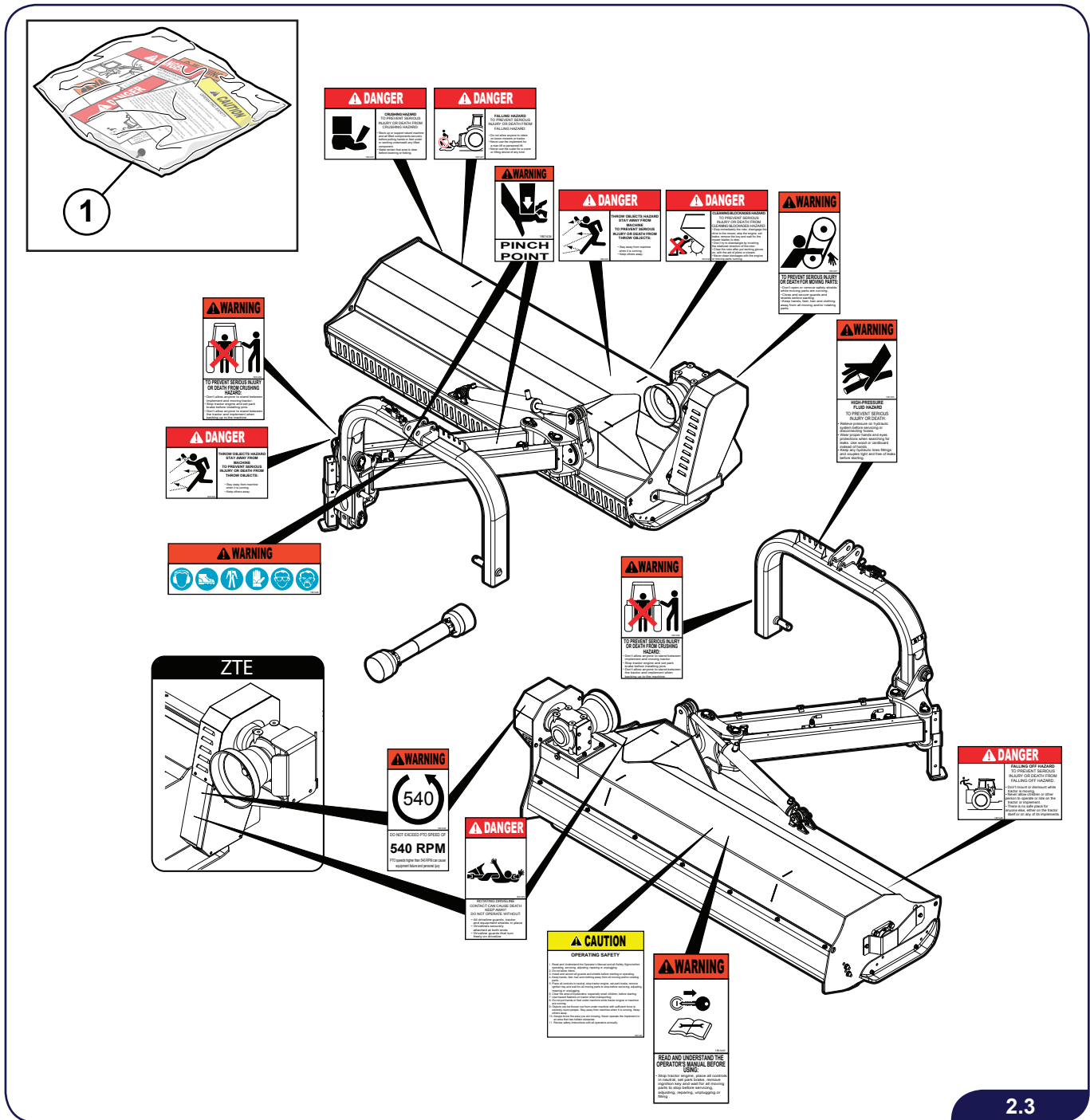

02-Pittogrammi di sicurezza ANSI

2.3

3 TECHNICAL FEATURES

3.1 General description of the machine

The ZT and ZTE model SHREDDERS are designed, built and equipped with guards for use exclusively in the agricultural and road maintenance sectors for cutting grass, reeds, bushes and shrubs with a diameter of up to approx. 4 cm (1.57 in).

All necessary measures are taken in design and construction to ensure a high-quality, reliable product, in compliance with the regulations in force and with particular attention to accident prevention.

The machines to which this manual refers are hitched to a tractor via a three-point connection and they work on the ground by virtue of their weight and the rotation of the flail rotor activated by the power take-off.

These machines consist of a structure on which the working part consists of a rotor with horizontal axles. The contoured flails are connected to the rotor and rotate at a higher speed than that of the machine's forward motion.

The machines are equipped with a system for adjustment of the working height, achieved by means of lateral runners and a rear roller.

The machine is not recommended for use in sectors other than agriculture and road maintenance.



The machine must be used by one operator only.
Any use other than that specified is to be considered unauthorized and dangerous (improper use).

3.1.1 Proper and improper use of the machine



FOR SAFETY REASONS IT IS STRICTLY FORBIDDEN TO USE THE MACHINE IN CONDITIONS OTHER THAN THOSE RECOMMENDED

The materials used in construction of the machine were chosen on the basis of the specific use for which it was designed and built. Improper use could cause damage to persons and/or property and jeopardize its correct operation.

Respect of the instructions for use, repair and maintenance described in this manual is an essential aspect of the use foreseen for the machine.

Use of the machine for activities not foreseen during its design and not expressly indicated in this manual releases FERRI srl from any direct or indirect liability.

Any arbitrary alteration to the machine also releases FERRI srl from all liability for any even serious damage or injury to operators, third parties and/or property.

Correct use of the machine and scrupulous respect of the instructions in the manual, and the strict application of all the precautions specified prevents situations of risk of accident or injury from arising, extends the machine's working life, improves results, and minimizes malfunctions.



FERRI srl is not responsible for any damage caused by failure to comply with the instructions in this manual.

3.2 Machine identification

An identifying plate is fastened to the machine and contains the main technical data, i.e.:

- 1) Manufacturer's name and address;
- 2) Serial number;
- 3) Year of construction;
- 4) Machine weight;
- 5) Transmission power;
- 6) Maximum hydraulic pressure.

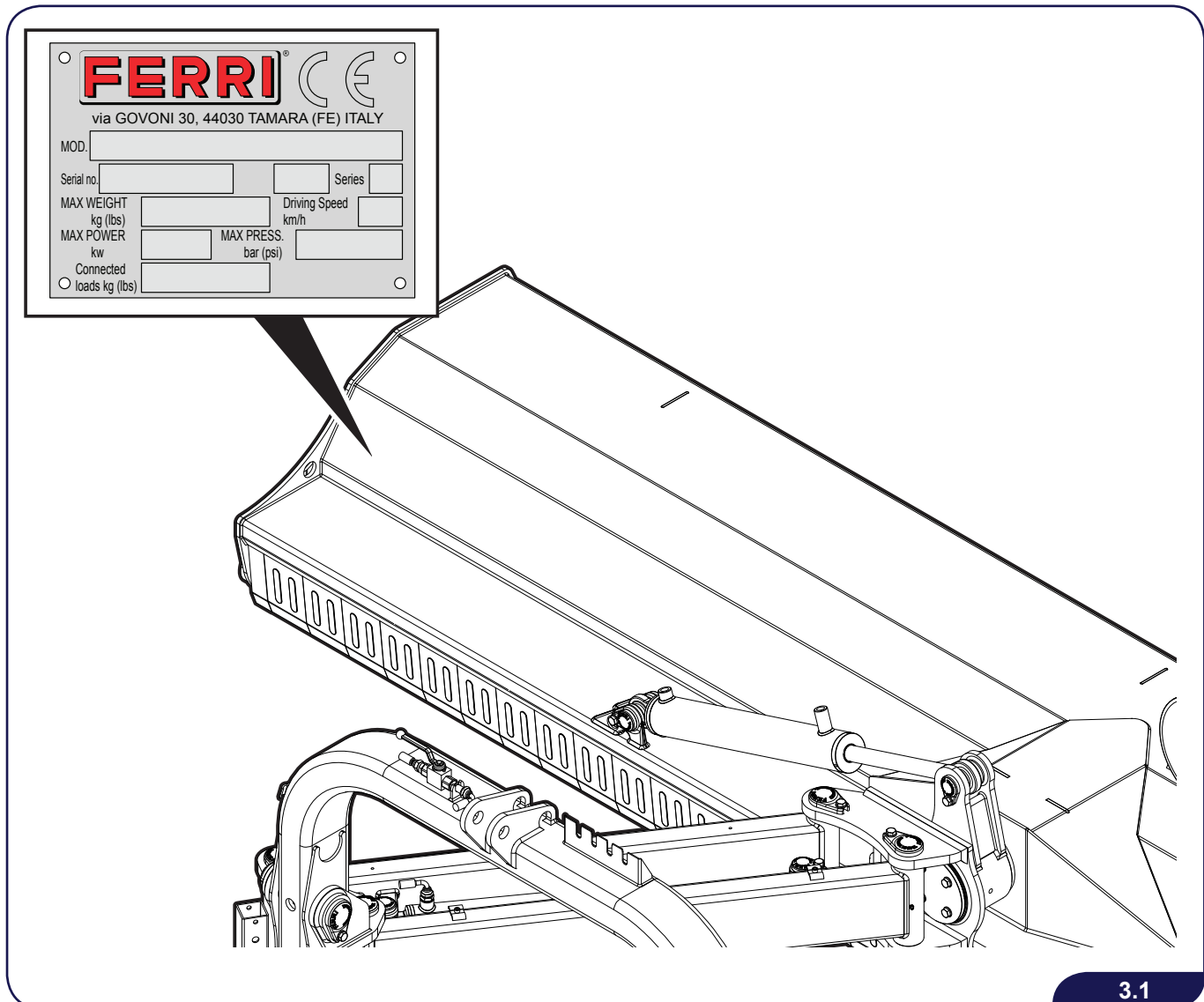

03-Posizione targhetta CE



The data given on the identification plate are indispensable when ordering spare parts.

3.3 Names of the parts

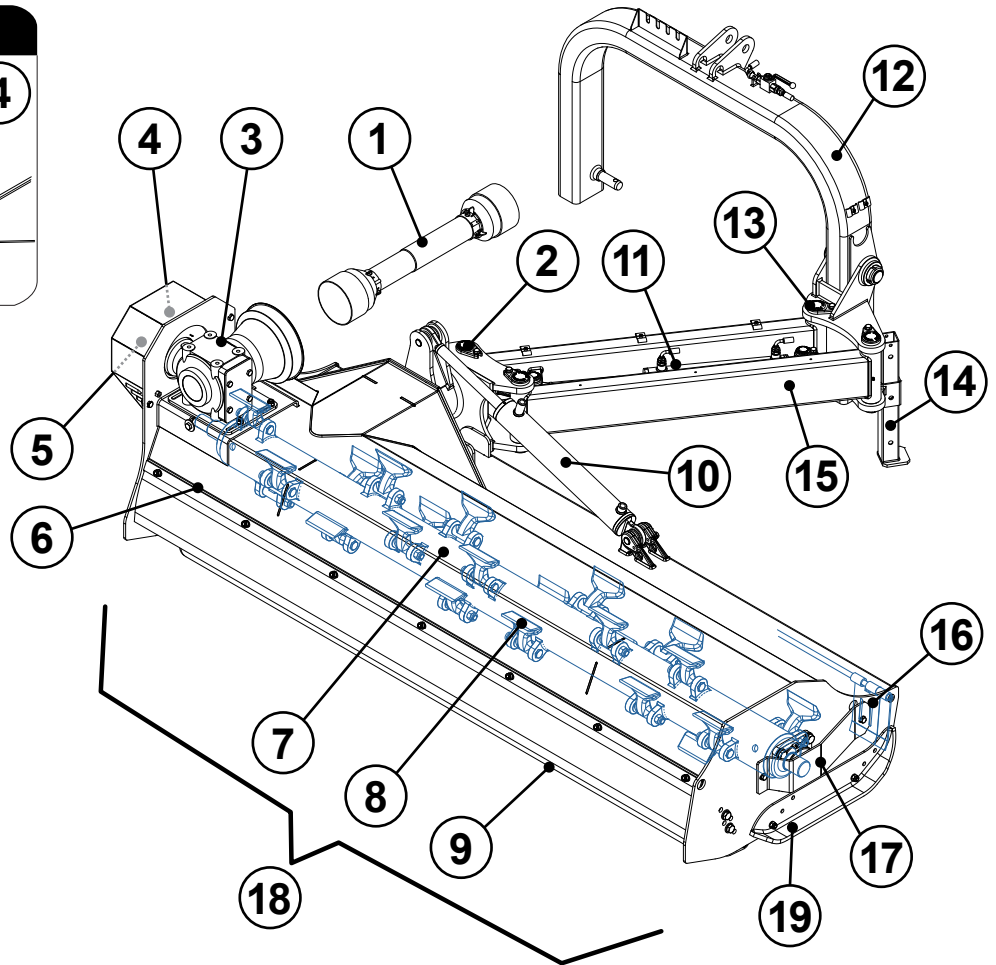
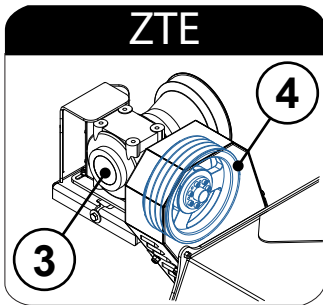

03-Dati tecnici (ZT-ZTE)

3.2

1	PTO shaft	11	Hydraulic ram for lateral movement
2	Flail head orientation articulation	12	3 point coupling
3	Gearbox	13	Arms support articulation
4	Pulleys	14	Support foot
5	Belts	15	Arms for lateral movement
6	Rear guard	16	Front guard
7	Flail shaft	17	Rotor bearing guard
8	Flails	18	Shredding flail head
9	Roller	19	Runners (optional)
10	Flail head orientation hydraulic ram		

3.4 Technical data

TAB 1		
Model		ZT2300 / ZTE2300
Width of cut	cm (in)	225 (89)
Minimum tractor width	cm (in)	220 (86)
Min-Max tractor power required	HP (KW)	70/80 (51,5/58,9)
Min. tractor weight	Kg (lbs)	2600 (5720)
PTO speed	rpm	540
Max. absorbed power (*)	HP (KW)	52 (38)
Machine weight/PTO weight	Kg (lbs)	701/29 (1545/63,9)
Coupling to tractor	cat.	II
Rotor speed	rpm	2325
Peripheral speed	m/sec	50
Multi-use flails	N.	66
Mauls	N.	22
Articulated flails	N.	96
Hydraulic system pressure	Bar (PSI)	190 (2750)
Hydraulic oil	type	ISO-L-HM68
Belts	N.	4

(*) For jobs where absorption exceeds the maximum power indicated, it is advisable to use a PTO shaft with clutch (torque limiter).

		ZT2300	ZTE2300
A	m	2,48	2,78
	ft	8' 2"	9' 1"
B	m	0,86	0,86
	ft	2' 10"	2' 10"
C	m	0,87	0,77
	ft	2' 10"	2' 6"

ZT

ZTE

3.3

03-Dati tecnici (ZT-ZTE)

3.5 Noise level

Measurement of the noise level is done on all models of machines produced by FERRI. The noise values indicated are emission levels and do not necessarily represent safe operating levels. The relationship between emission levels and exposure levels cannot be reliably used to establish whether further precautions are required or not. The factors which determine the exposure level to which the operator may be subject include duration of the exposure, characteristics of the work environment and other sources of noise (number of machines, nearby activities, etc). Moreover, admissible exposure levels may vary from one country to another. The information provided will enable the user to determine the danger and risk to which he is subject.

	Noise level (LPA)	Acoustic power (LWA)
Closed cab	75 - 78,5 dB(A)	102,5 dB(A)
Open cab	82,9 - 84,4 dB(A)	\

The tests were carried out on a tractor (or vehicle) chosen at random. The data may vary depending on the application.



Use personal safety gear (ear plugs) if the noise level exceeds 85 dB or the machine is used on a tractor without a cab or with a cab with the windows open. Prolonged exposure to noise can cause serious hearing damage (noise levels over 85 dB) or cause partial or permanent hearing loss (noise levels over 90 dB).



According to the data measured in the various positions examined, in the absence of a soundproofed cab we recommend using individual hearing protection.

03-Rumorosità

3.6 Working range

The data relative to the working range covered by the machine are listed below.

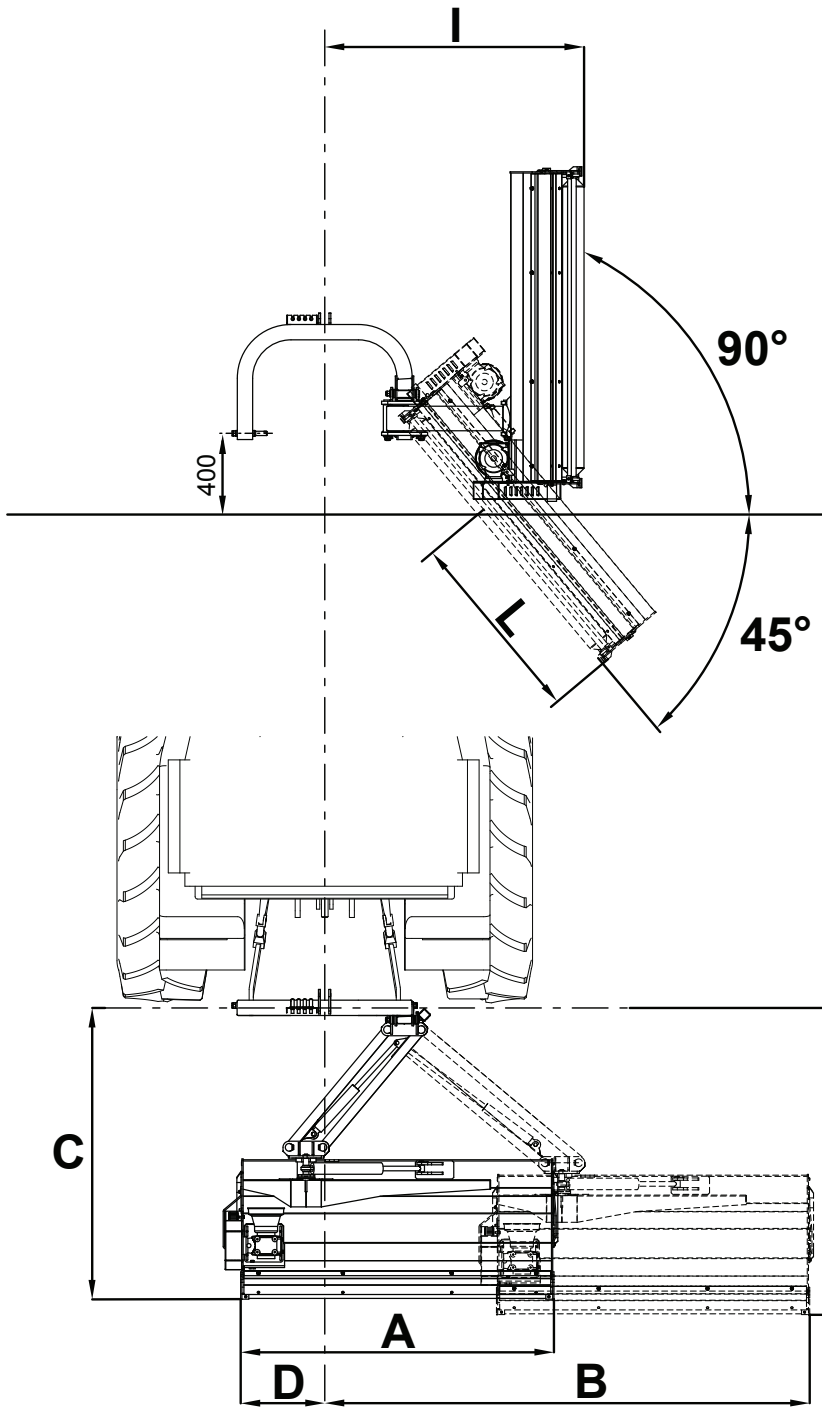

TAB 2		ZT	ZTE
A	m	2,25	2,25
	ft.	7' 5"	7' 5"
B	m	2,94	3,27
	ft.	9' 8"	10' 9"
C	m	1,79	1,79
	ft.	5' 10"	5' 10"
D	m	0,63	0,30
	ft.	2' 1"	0,81"
H	m	1,92	1,92
	ft.	6' 4"	6' 4"
I	m	1,50	1,50
	ft.	4' 11"	4' 11"
L	m	1,66	1,99
	ft.	5' 5"	6' 6"

03-Raggio di lavoro

3.7 Variations

3.7.1 Flails

Depending on the type of material to cut, use the most appropriate flails.
The following table lists the cutting flails that can be fitted on the shredder (and their characteristics).

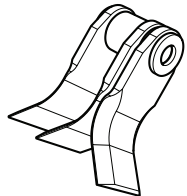
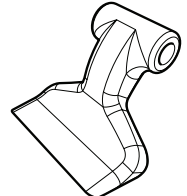
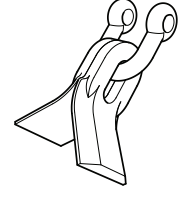
TYPE OF CUTTING FLAILS		
DESCRIPTION		
INTERCHANGEABLE ON THE SAME ROTOR	Multi-use “Y” flails for grass, canes, shrubs and bushes up to 3 cm (1.18 in) in diameter.	
	Mauls for grass, wood and vines up to 4 cm (1.57 in) in diameter.	
	Articulated “Y” flails for grass, canes and shrubs up to 2 cm (0.78 in) in diameter.	

03-Utensili (ZT-ZTE)

NOTE: Do not use on stony terrain.



If any irregularities and/or strange noises are noticed after changing the flails, contact the Manufacturer.

3.7.2 Controls with distributor

For tractors equipped with only one oil pressure tap or on specific demand by the customer, it is possible to fit a two lever control distributor (A) with flexible pipes, also envisaged with the float system for operating the hydraulic ram (1).

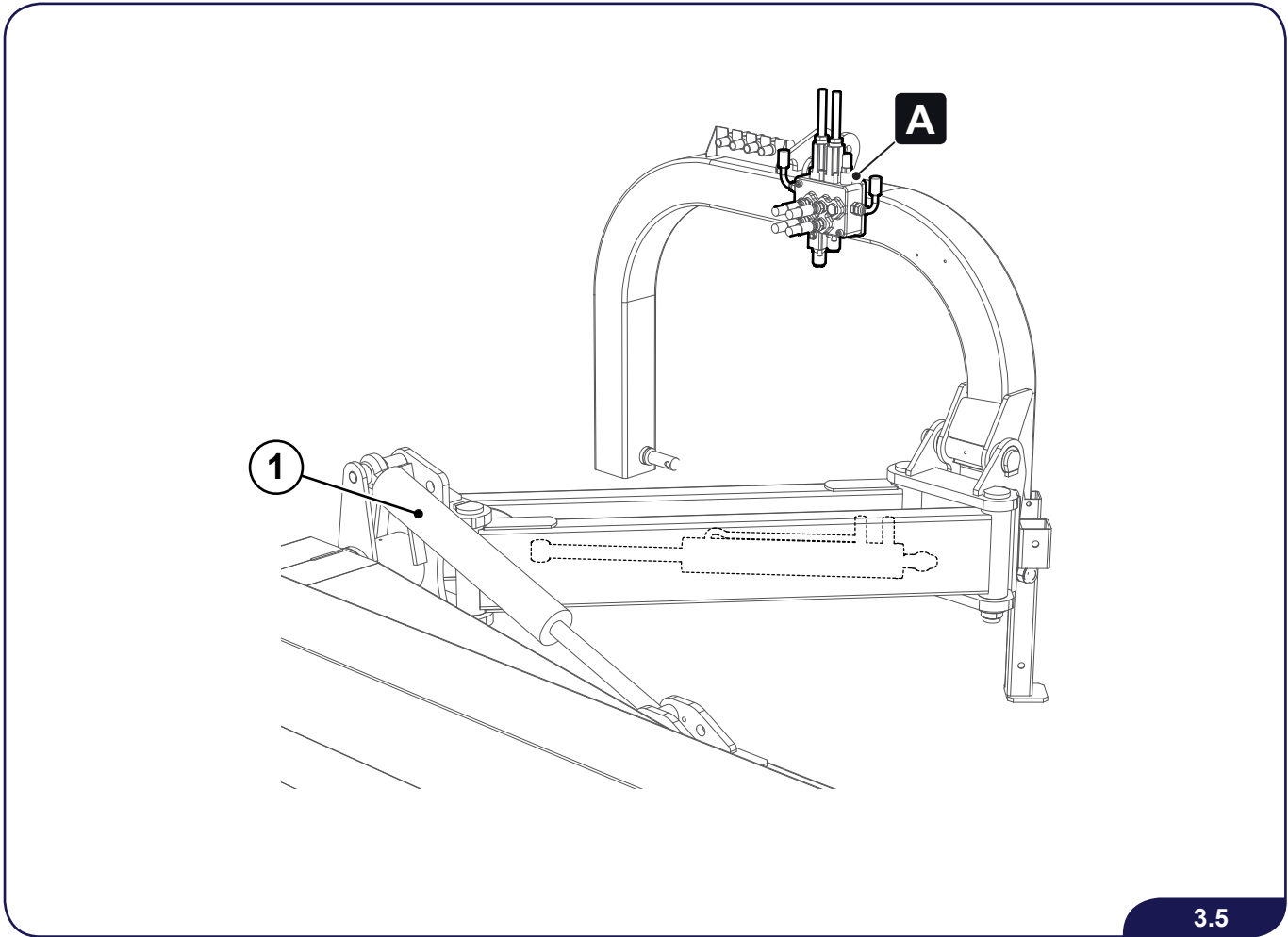

03-Comandi con distributore

3.5

3.7.3 Runners (Optional)

The runners (1) serve to:

- 1) Adjust the working height of the machine, in combination with the standing roller (see Chapter 5);
- 2) Prevent excess wear on the cutting flails.

03-Varianti (Slitte)

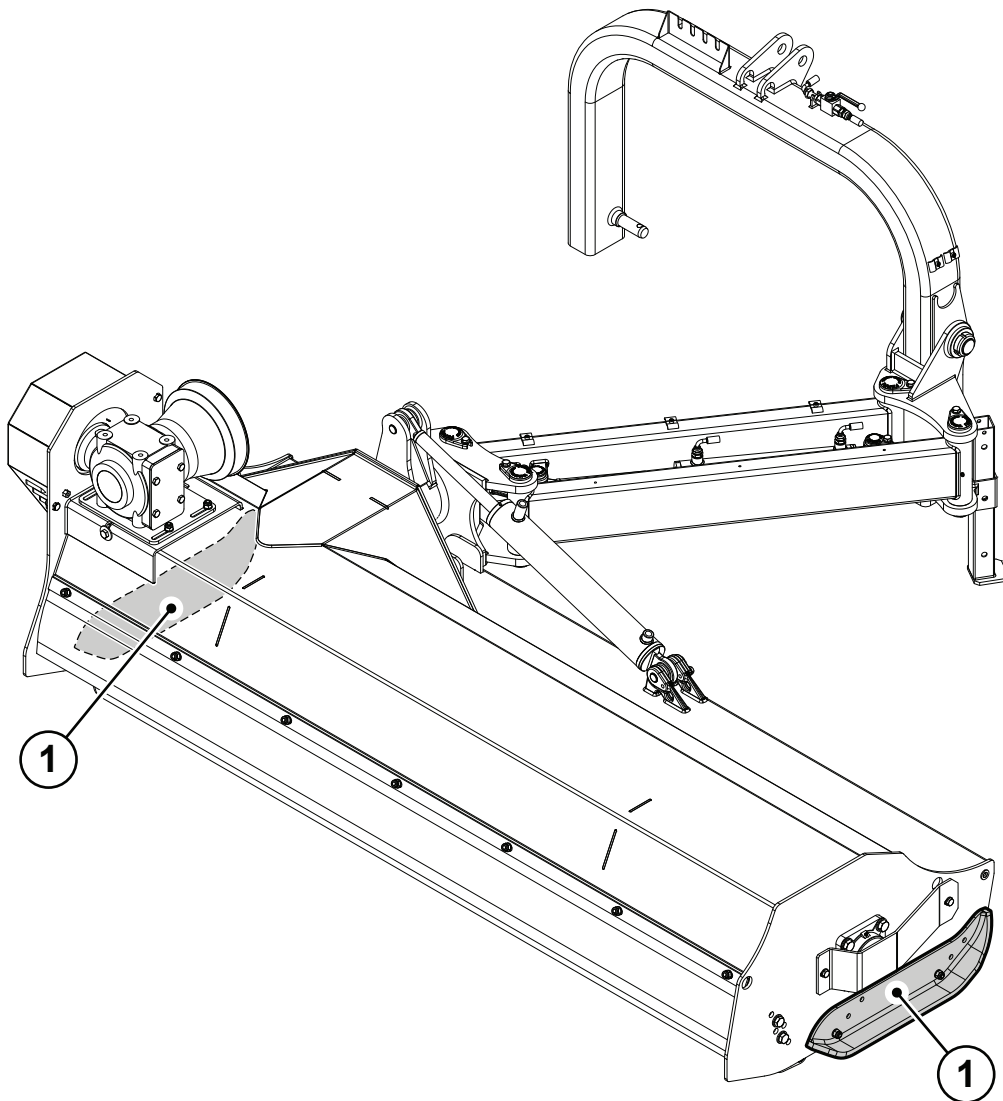

3.6

Page left blank intentionally

03-Varianti (Slitte)

4 INSTALLATION AND HANDLING



Wear safety footwear, overalls, safety gloves and, if necessary, earplugs and a face mask during operations of maintenance, repair, movement or storage of the machine.

4.1 *Hoisting*



WARNING

To hoist the machine, use safety hooks and cables of adequate load capacity to be introduced in the points indicated for hoisting in the decals applied on the machine.

The machine may also be placed on a wooden pallet and suitably anchored to it.
Any subsequent handling of the machine must be carried out exclusively by means of a fork-lift truck.
Handling operations must be carried out by qualified, trained personnel (crane operators, forklift operators, etc.).

04-Sollevamento

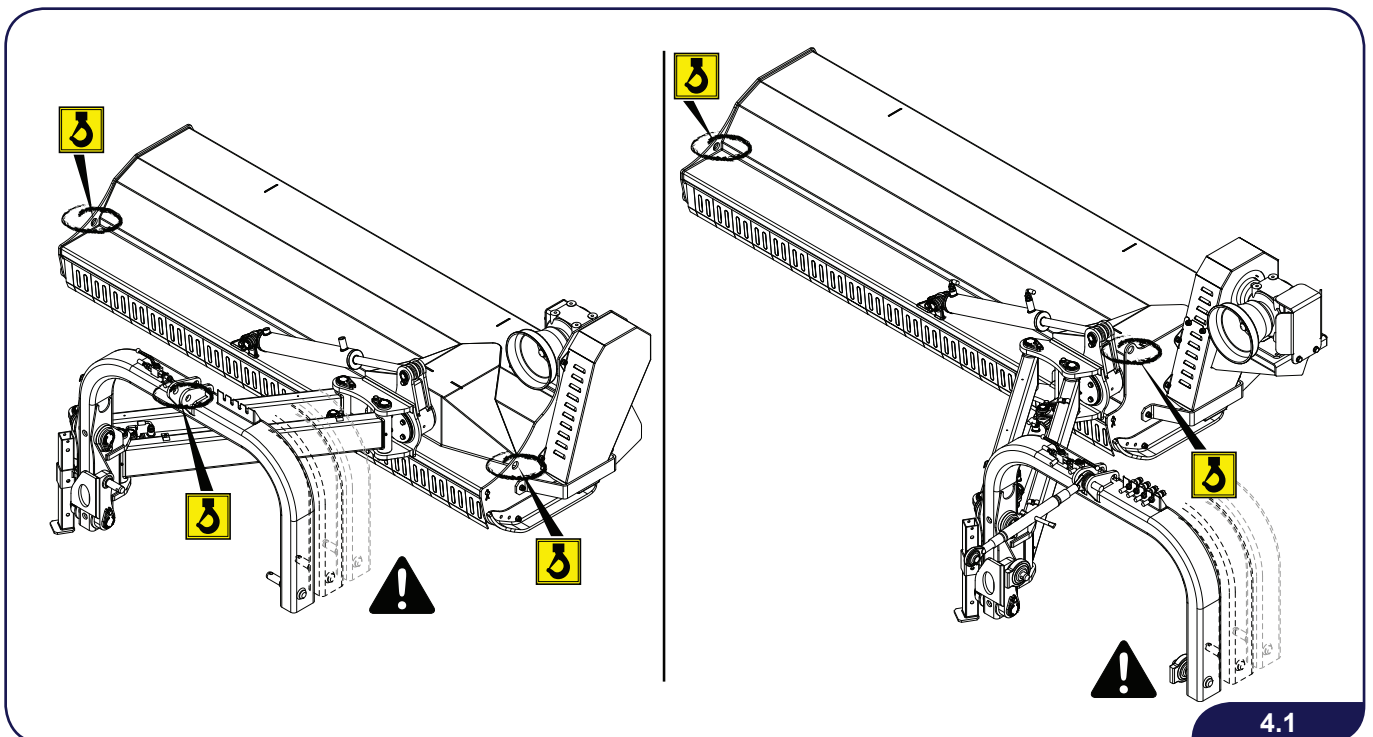

4.1



WARNING

Hoisting is a delicate maneuver, always carried out at the user's risk.

4.2 Removal of packing materials

During shipment, parts of the machine are dismantled for packing.

The machine stands with the rear roller and two supporting feed on a wooden pallet to which it is strapped with iron wires to ensure its stability.

Before it can be installed and used, precise operations of assembly of the dismantled parts must be carried out.

To perform the operations of moving and handling the machine safely, use a forklift and/or winch/hoist with sufficient capacity to carry the weight of the machine (see Chapter 3).



Handling operations must be carried out by qualified, trained personnel (crane operators, forklift operators, etc.).

- 1) Place the pallet on a flat, dry surface.
- 2) Before removing the iron wires fastening the parts of the machine dismantled from it, place them in the slings connected to the winch to prevent them from falling.



04-Rimozione imballo (ZT-ZTE)

4.2

- 3) Fasten the third point arc (1) in place using a strap or chain of adequate load capacity before cutting the fastening wire applied.
- 4) Keep the strap or chain tight in order to prevent the arc (1) from falling.
- 5) Fasten the hoisting hook to the hole (A) in the third point arc (1).
- 6) Fasten the third point arc (1), hoist it and position it flat on the ground at a due distance so as not to interfere with assembly of the machine.

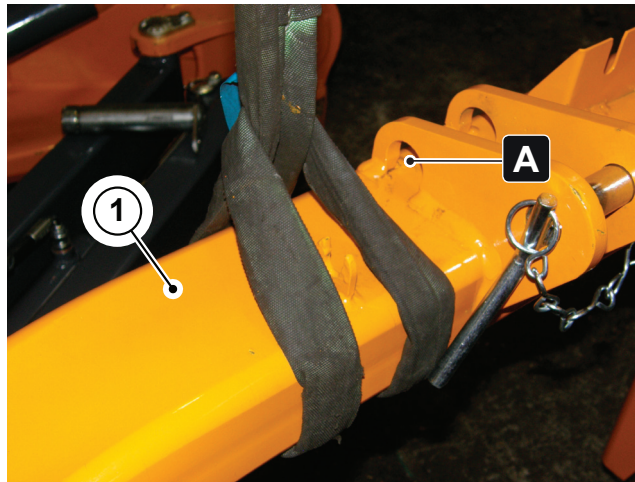

4.3

04-Rimozione imballo (ZT-ZTE)

- 7) Remove the PTO (2) laid inside the machine chassis and fastened to it with straps.
- 8) Place the PTO flat on the ground at a due distance so as not to interfere with assembly of the machine.
- 9) Fasten the machine at the points provided for hoisting it (indicated in the preceding paragraph).

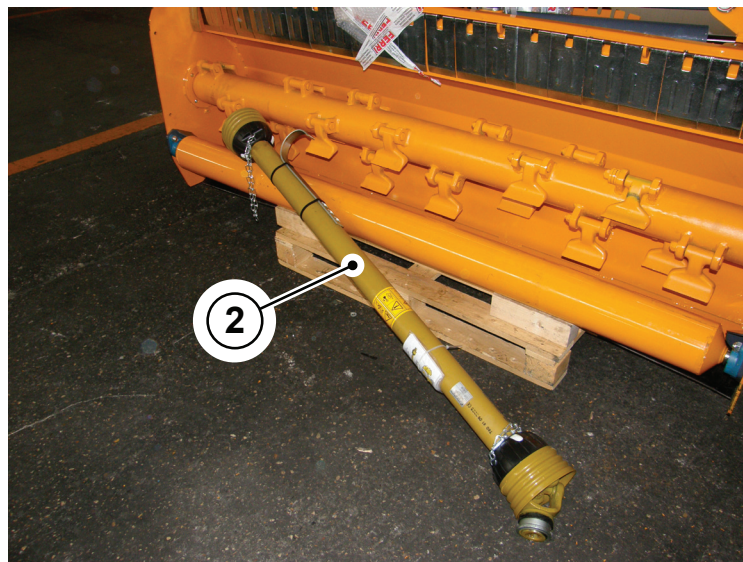

4.4



Connecting the machine to any other lifting points is extremely dangerous.

- 10) Cut all the wires fastening the machine and its parts and remove them.
- 11) Unscrew the screws (3) fastening the shipping brackets (4) to the wooden pallet.



4.5

- 12) Hoist the machine with a winch/elevator of adequate load capacity (as shown in the figure), and move it away from the wooden pallet, then lower it slowly to the ground. With this type of fastening the machine tends to position itself horizontally and can be set gently on the ground.
- 13) Remove the shipping brackets (4).



4.6

04-Rimozione imballo (ZT-ZTE)

- 14) Fasten and hoist both arms of the machine using an elevator.
- 15) Open the arms.
- 16) Fasten the arm in place with the relative pin and lock ring.
- 17) Block the pin (5) with the screw.
- 18) Position the supporting foot of the machine by fastening the pin in the central position (P).

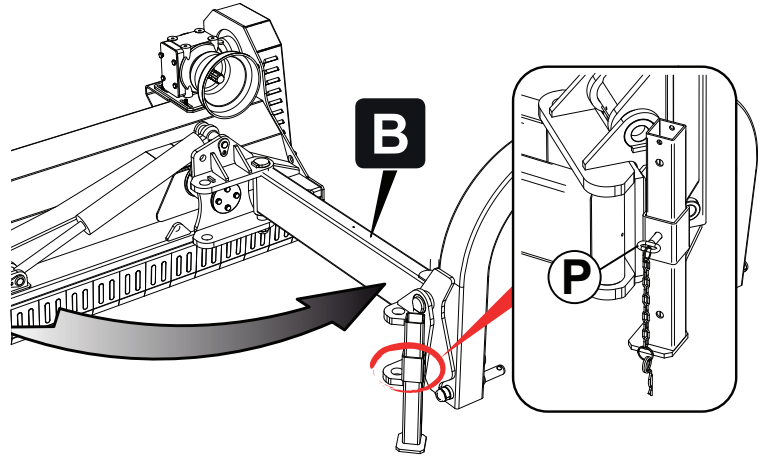
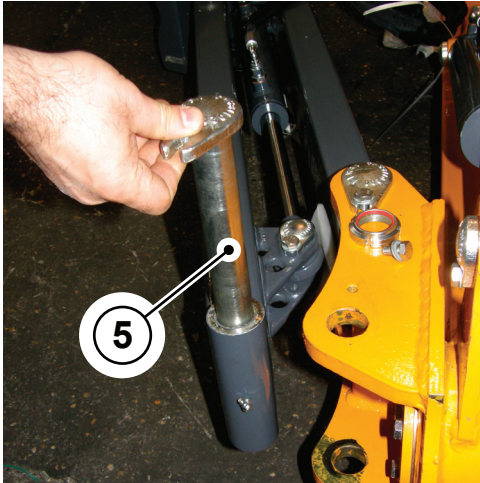

4.7

04-Rimozione imballo (ZT-ZTE)

- 19) Hoist the arc by fastening it with a chain or belt (as shown in the figure). If the chain is equipped with a hook, this should be fastened to one of the holes in the 3-point fastener.
- 20) Bring the three-point arc fastener to the machine, specifically near the terminal section of the parallel arms. Holding the arc raised, position it at the arm fastener so that the pin can fit between the fastener and the arms unit. Insert and fasten the special pin and block it with the screw and lock ring provided.

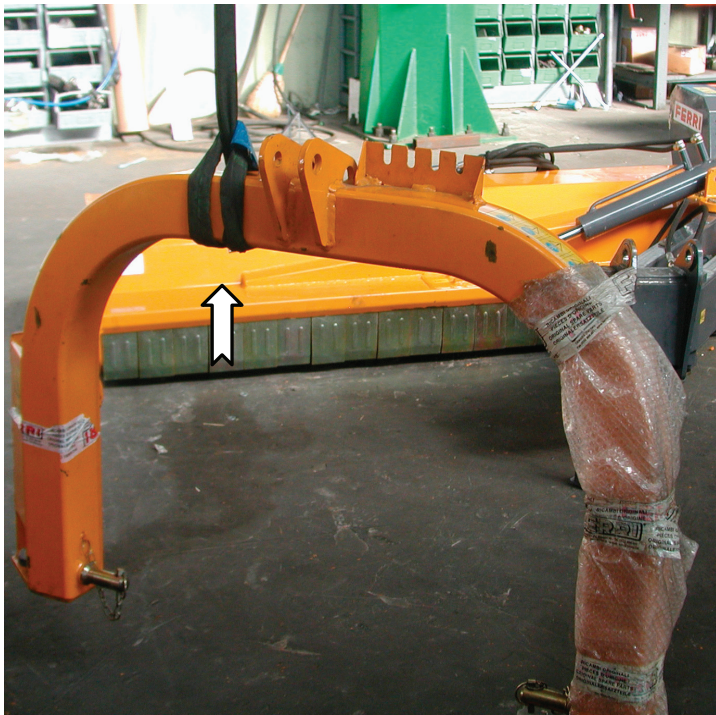

4.8

21) Install the hydraulic hoses passing them along the arm (A) and fastening them with the clamps provided.

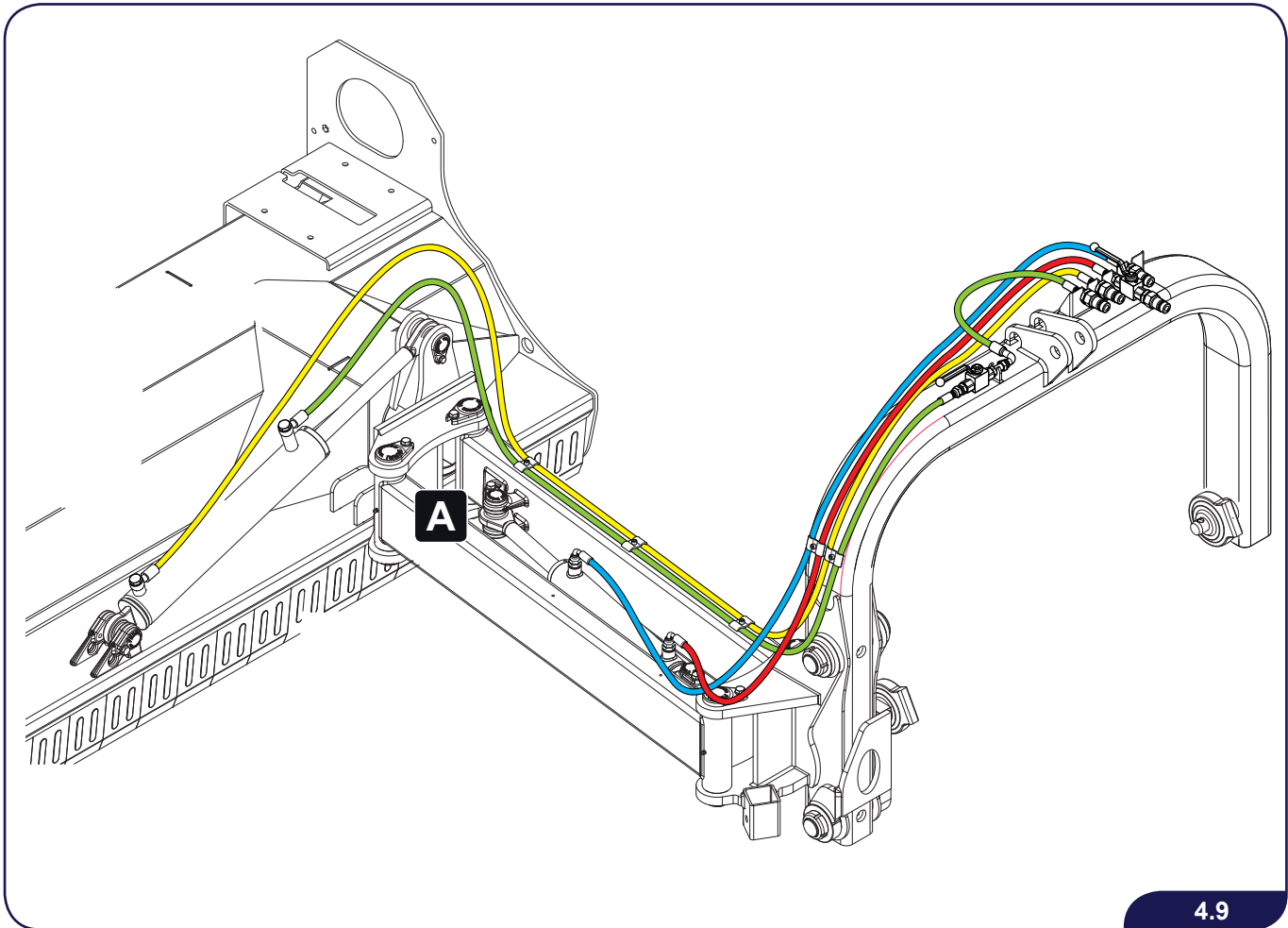

4.9

04-Rimozione imballo (ZT-ZTE)



FERRI is not responsible for any damage caused by improper assembly of the parts described in this paragraph.

4.3 Coupling to tractor



Before coupling the machine to the tractor, make sure:

- A) All the controls have been disengaged;
- B) The tractors engine is off;
- C) The parking brake has been set;
- D) The ignition key has been removed from the dashboard;
- E) All moving parts have come to a complete stop.

Provide lighting in the work areas whenever visibility is scarce.

Keep all unauthorized people at least 5 meters (16' 5" ft) away from the coupling point during coupling operations.



Position the tractor on flat, compact terrain to prevent lateral overloading of stabilizers.

- ▶ Before connecting the machine to the three-point coupling on the tractor, position the safety device on the lifting arm so as to make involuntary and/or accidental raising or lowering impossible.
- ▶ The three-point coupling on the tractor and machine must coincide. If not, adjust them.



There is a risk of injury due to the presence of points where crushing and cutting can occur near the tractor elevator arm linkage system.
Do not use the external control for raise the machine.



During coupling, do not allow anyone to stand between the tractor and the machine.

4.3.1 Attaching without a Quick Hitch

- 1) Bring the tractor close to the machine until the 2 arms (1) of the hydraulic elevator on the tractor coincide with the machine couplings (2).
- 2) Fit the arms of the elevator in the couplings (2) and lock with the security pins (3).
- 3) Fit the third point stabilizer (4). Raise the machine and regulate until the third point arc (7) is perpendicular to the ground. Stiffen the 2 arms (1) of the elevator with the respective stabilizers (5), positioning the machine in the center.
- 4) Make sure the retainers used on all mounting pins have been securely locked.
- 5) Raise the support foot (6) (if any).
- 6) Connect the oil pipes on the controls of the hydraulic rams to the tractor, taking care not to invert the pipes during assembly.

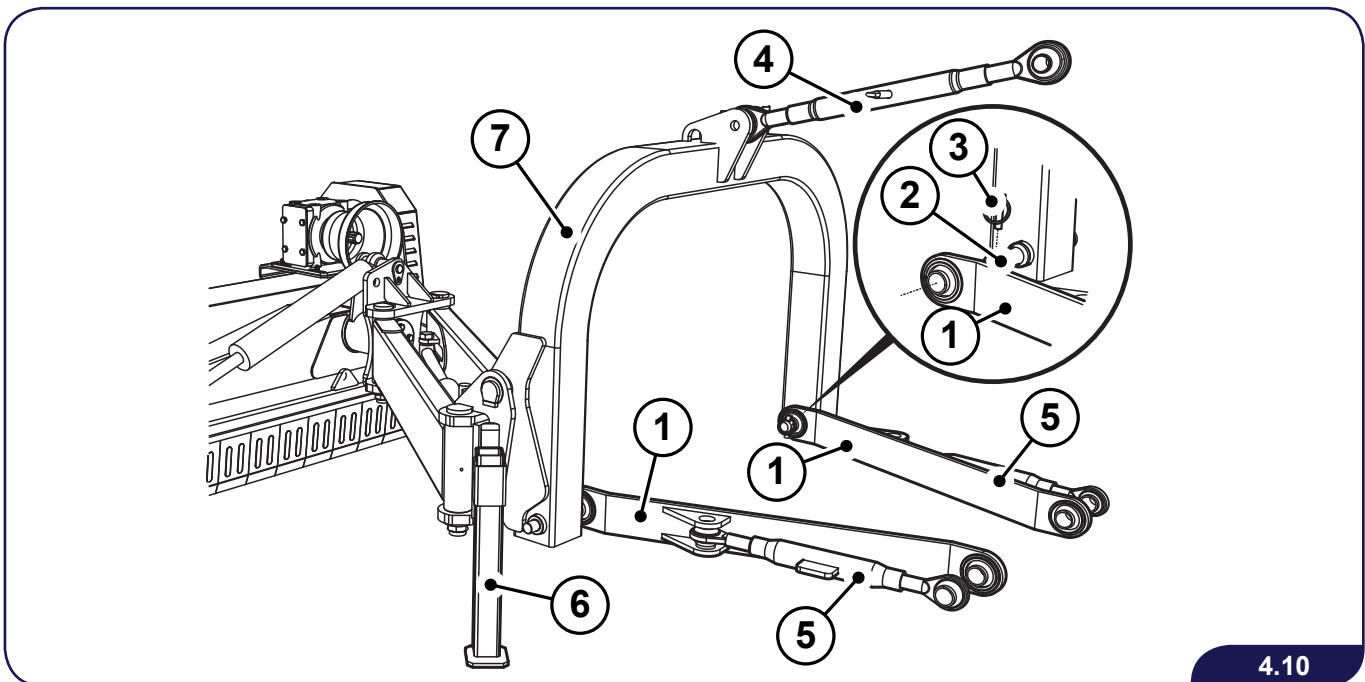

04-Aggancio (Trinciatrici)

4.10

4.3.2 Attaching with a Quick Hitch

- 1) Set the height of the hydraulic elevator arms of the tractor so that the elevator hooks are lower than the mounting pins on the machine.
- 2) Make sure the 3 pins on the hitch are installed correctly.
- 3) Align the hooks on the hydraulic elevator of the tractor while slowly backing up.
- 4) When the hooks are under the pins, slowly raise the 3 point hitch. Make sure the quick hitch fasteners on the hydraulic elevator of the tractor fit correctly into the pins on the 3-point hitch of the machine
- 5) Fasten the locks on the hydraulic elevator hooks.
- 6) Connect the oil pipes on the controls of the hydraulic rams to the tractor, taking care not to invert the pipes during assembly.



Insert the security pins into the hole and lock them in place, making sure that they are effectively locked. Also lock the third point coupling anti-unscrew device.



Do not work with the flail head tilted toward the front or rear, so as not to alter the effectiveness of the safety guards installed on the machine. The flail head should be parallel to the ground during operation.

4.3.3 Hydraulic connections for lateral movement

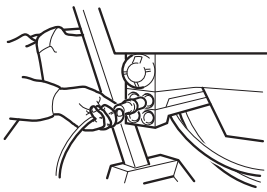

Make sure the hydraulic hoses are correctly fastened and installed. Their reversal causes movements opposite of those controlled.

- 1) Connect the quick coupling hydraulic hoses to the tractor after checking that all the connections are clean and in perfect condition.
- 2) Fit the male fittings to the quick hitches on the tractor. Make sure they are securely fastened.
- 3) Apply pressure to the hydraulic system and if there are any leaks, take the necessary precautions to prevent accidents.
- 4) Pressurized liquids, especially the oil in a hydraulic circuit, can cause severe injuries and produce infections. In case of accidents, see a doctor.
- 5) As soon as the shredding operations are complete, the hydraulic hoses, uncoupled from the tractor, should be fastened to the supports provided.
- 6) Use a clean cloth to clean the ends of the hoses and the area around the quick hitches of the tractor.
- 7) Before doing any work on the hydraulic system, switch off the tractor engine (if on) and bleed out any residual pressure from the circuit.
- 8) Dispose of used oil and grease correctly. Deliver them to the special disposal centers.

04-Collegamenti idraulici spostamento laterale (con rotazione)

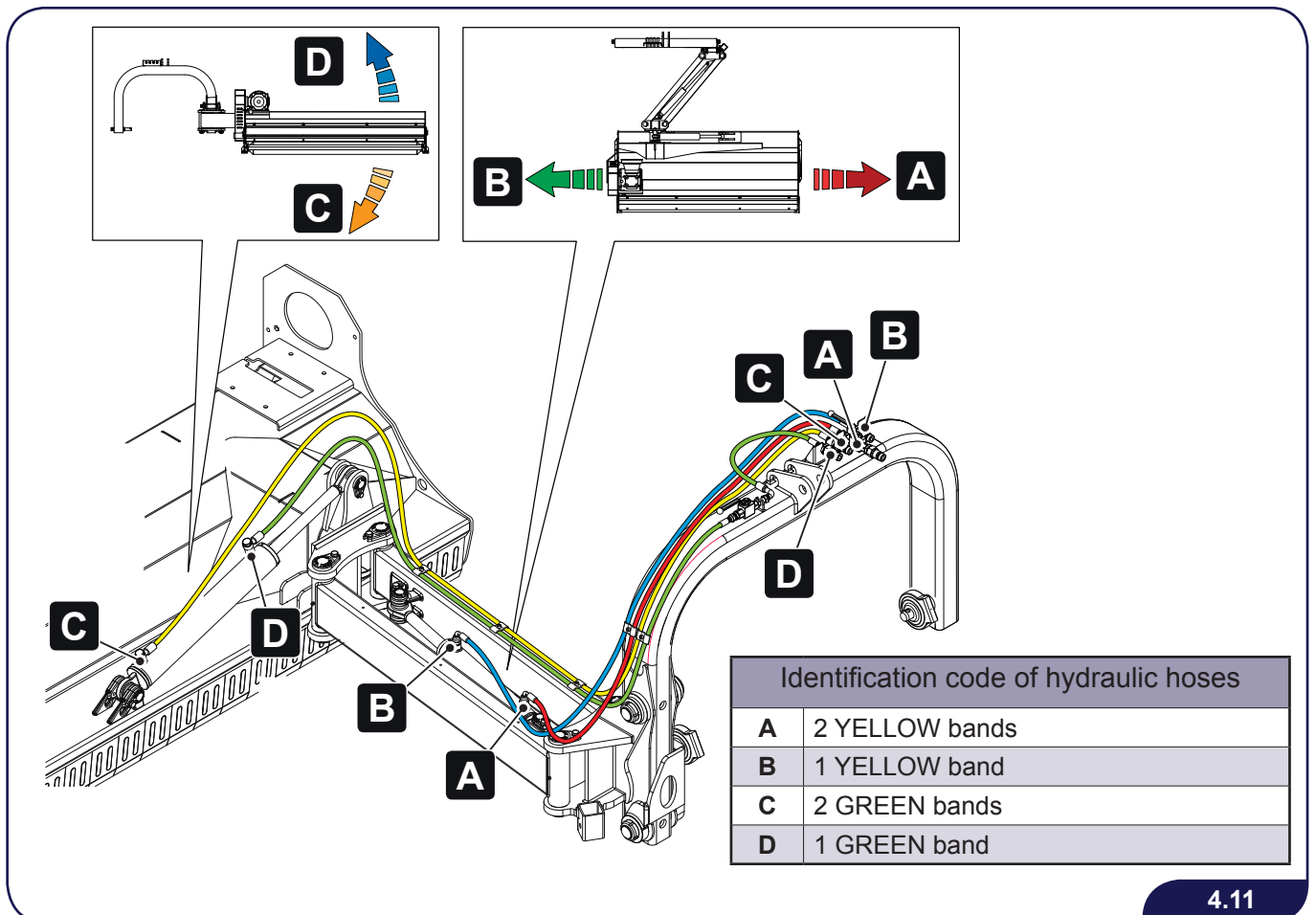

4.11

4.4 Fitting the PTO shaft

Before using the PTO shaft, read the use and maintenance manual carefully.

PTO SHAFT SPECIFICATIONS	
No. of Grooves	6
Connector	1" 3/8

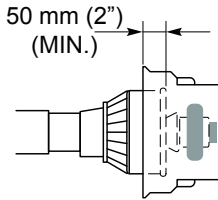

If the PTO shaft supplied with the machine is not used, check that the cowlings of the machine and of the tractor are overlapped on the guard of the PTO shaft by at least the amount contemplated in the safety regulations in force (50 mm/1.97 in).



Do not exceed a PTO shaft angle of 15°. Operating at more than 15° will reduce the PTO shaft life by 75% and invalidate the guarantee.
 If it is necessary to work with higher angles, use a PTO shaft with double homokinetic articulation.
 If the same equipment is used on different tractors (with or without Quick-Hitch), use different drivelines.
 A Quick-Hitch will change the distance between the tractor shaft and the PTO shaft. Measure the distance between the due hitches.

Use only PTO transmission shafts with perfectly intact guards.
 The length of the PTO shaft must be appropriate for the type of tractor used.
 When the PTO shaft is disconnected from the tractor power takeoff, it must ALWAYS be placed on its support.



For correct and safe operation of the machine, use only PTO shafts bearing the CE mark.



Check the direction of rotation and the number of rpm of the tractor p.t.o. before fitting the PTO shaft.



Before leaving the driver's seat of the tractor and performing any operation, apply the parking brake and disengage the PTO. Switch off the engine and remove the ignition key from the dashboard.



Never pass beyond the PTO shaft area (with or without the PTO shaft in movement).

When the machine is connected to the tractor for the first time, follow these instructions carefully:

- ▶ In the condition of maximum steering, the PTO shaft must not be completely closed in order to prevent damage to the gearbox. If the PTO shaft is too long, shorten it as described in this paragraph.
- ▶ Check that the towing eyebolt is positioned at the best height for connection to the tractor. If not, adjust the height of the eyebolt as needed.
- ▶ Move the PTO shaft to a horizontal position to prevent potential disengagement, which could cause an accident or damage the guards.
- ▶ Clean and lubricate the power take-off and gearbox fitting.
- ▶ Grease the PTO shaft, if necessary. Follow the instructions provided by the PTO manufacturer (see the use and instruction manual for the PTO shaft).
- ▶ Using the hydraulic elevator on the tractor, place the machine in the closest point between the respective power take-offs and measure the length of the PTO shaft. The semi-shafts of the PTO must overlap by at least 1/3 of their length at the maximum extension, and must have a free span of at least 4 cm (1.57 in) at the maximum closure.

04-Montaggio albero cardanico

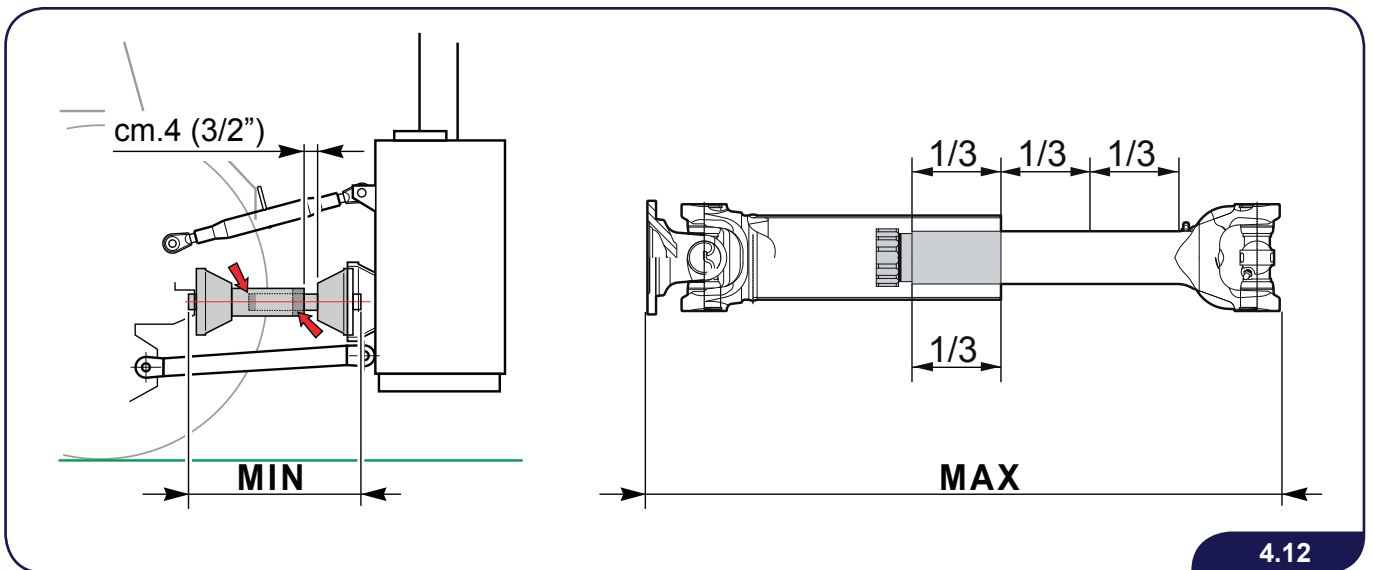

4.12

- ▶ Make sure that the length of overlap between the contoured pipes is not less than 2/3 of the stroke with the PTO shaft closed. If not, cut the excess part of both the telescopic pipes (A) and the guards (B). **Cut both sides the same length.**

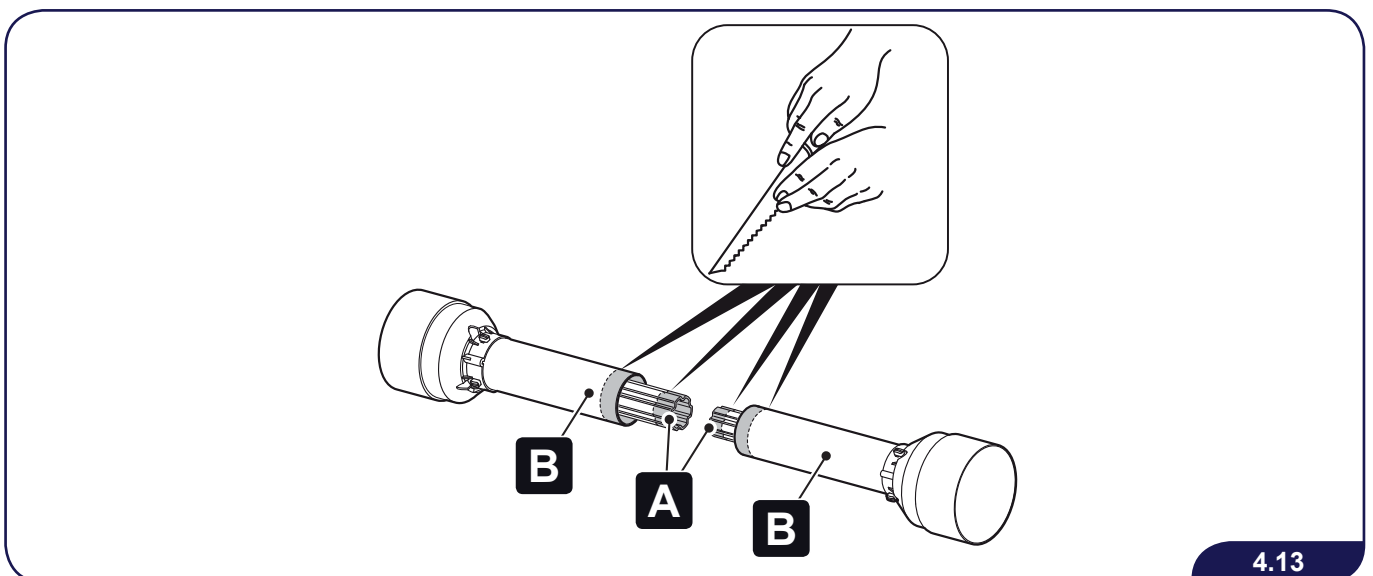

4.13

- ▶ Connect the PTO shaft to the gearbox on the machine. Respect the installation direction indicated by the manufacturer and shown on the outer casing of the guard and on the power take-off of the tractor.

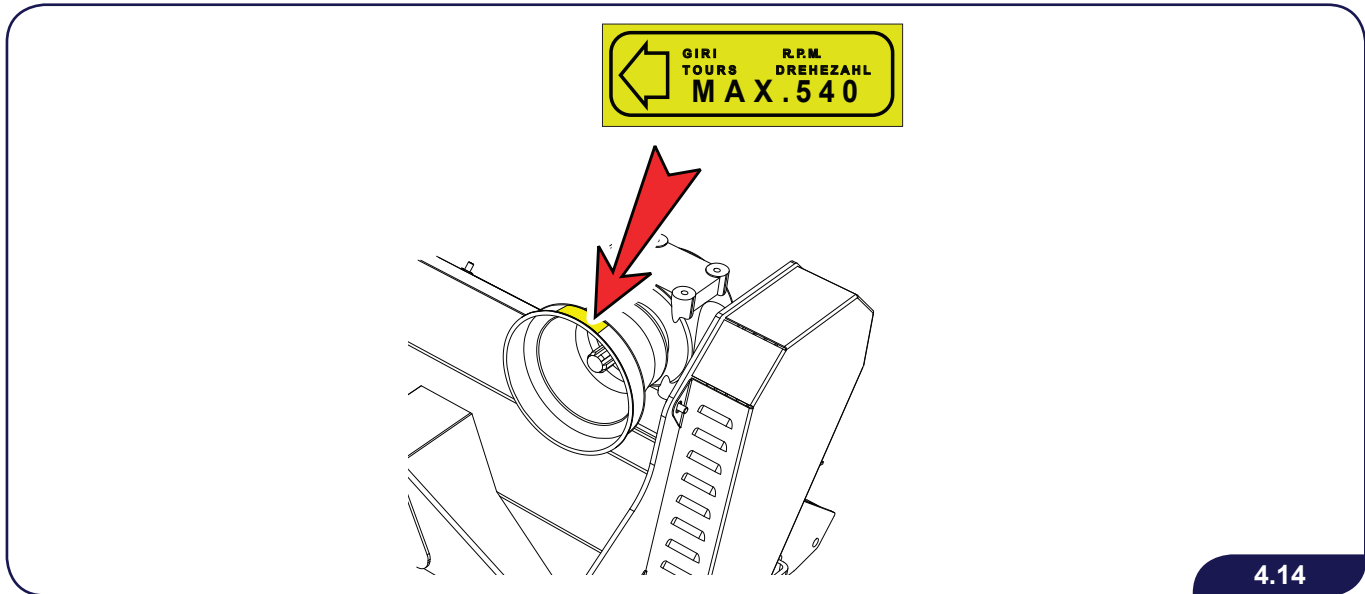

4.14



Always connect the PTO shaft last to the tractor PTO and disconnect it first after terminating the work.

- ▶ Fasten the guards of the PTO shaft to the machine and tractor with chains to prevent their rotation.
- ▶ Make sure the anti-removal safety block (key) is correctly inserted and blocked in its housing.
- ▶ The overlap between cowling and PTO shaft must not be less than 5 cm (1.97 in).
- ▶ To connect the machine to the tractor PTO shaft, pull the coupling collar back and align the splines with those of the PTO coupling.
- ▶ Push the fastener inside the PTO connector and release the connector collar. Move the fastener until it is correctly fitted to the PTO shaft.
- ▶ Push and pull the PTO shaft back and forth to ensure a secure attachment.
- ▶ Make sure the PTO shaft slides easily and the couplings rotate freely.



If the PTO shaft does not slide easily, take it apart and clean the splines then re-insert it. Make sure the couplings are phased and the splines fit properly in the grooves. If the shaft does not slide easily and the couplings are not aligned, forcing the shaft will damage it.

- ▶ Connect the PTO shaft to the tractor, after pulling out the security pin. Make sure the pin returns to the secure position so that the connection is correctly assembled. Make sure the coupling is locked in position.
- ▶ Always stop the power take-off when raising the machine or when the manoeuvring angles are too large.



FERRI is not responsible for damage caused by improper connection and use of the PTO shaft.

4.5 Balancing the tractor

Check the hoisting capacity and longitudinal stability of the tractor using the following formula. If necessary, apply ballast on the front.

To determine the total weight of the machine you must add the weight of all the components (see Chapter 3).

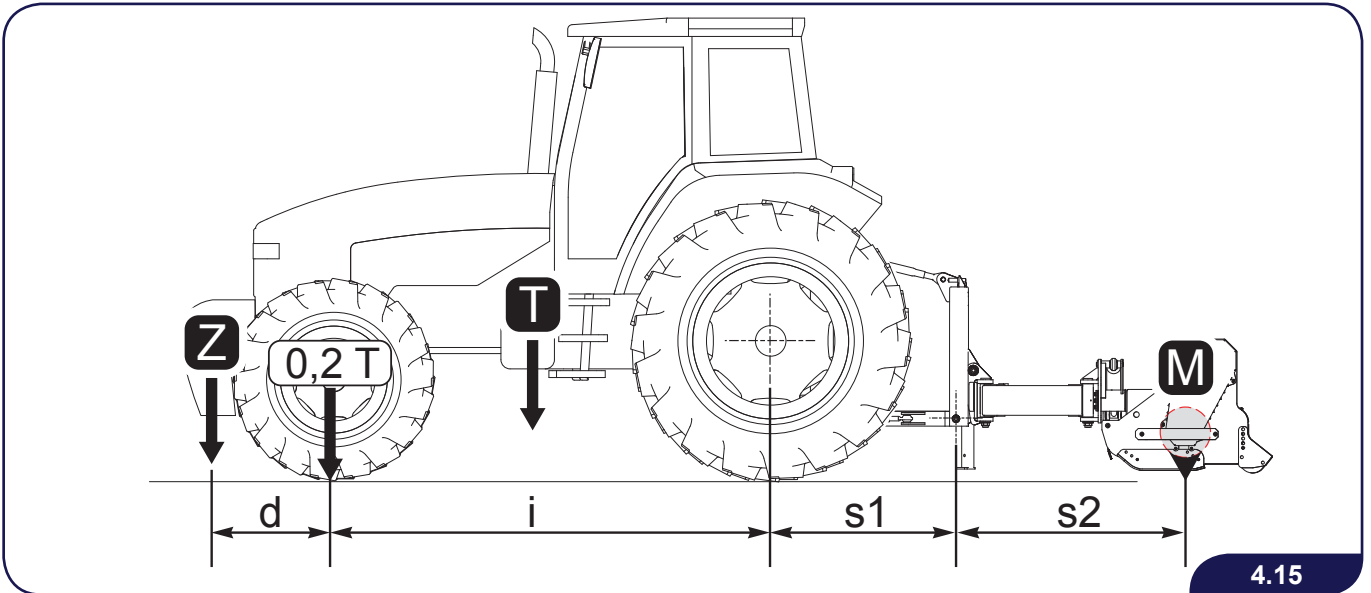

4.15

$$M \times (s1+s2) \leq 0.2 T \times i + Z(d+i)$$

$$M \leq 0.3 T$$

i	=	tractor wheel base
d	=	distance of front axle from ballasts
s1	=	overhang of the rear axle of the machine coupling points
s2	=	height of the machine coupling points from the center of gravity
T	=	weight of the tractor + 75 kg (operator)
Z	=	weight of ballasts
M	=	weight of fully loaded machine



WARNING

The front axle of the tractor is lightened in relation to the weight attached at the time of coupling to the shredder: **THE LOAD ON THE FRONT AXLE MUST BE AT LEAST 20% of the total tractor/equipment weight ready to be used.** Check the hoisting capacity and stability of the tractor to prevent its tipping and/or losing the grip of the steering wheels.

Hoist the machine completely and make sure the tractor does not pitch.

When the machine is in its maximum extension, check the tractor's stability: slowly open the arms and hold the shredding flail head as close as possible to the ground. If necessary, ballast the rear wheel of the tractor opposite the extended arm.



CAUTION

Do not work with the arms extended when the tractor is standing on sloping ground. During transport, move the flail head into central position.

4.6 *Disconnecting from the tractor*

Proceed as follows to disconnect the machine from the tractor:

- 1) Apply the tractor parking brake.
- 2) Close the arms (for lateral shredders).
- 3) Lower the machine supporting feet (if any) and lock them into place.
- 4) Set the machine on the ground using the hydraulic elevator on the tractor.
- 5) Disengage the tractor PTO.
- 6) Switch off the tractor engine.
- 7) Remove the ignition key from the dashboard.
- 8) Disconnect the PTO shaft by unfastening the locking bolts, and place it on its support.
- 9) Release the stabilizer of the third coupling point and remove the respective peg and pin.
- 10) Fasten the third coupling point to its support on the tractor.
- 11) Unfasten the hydraulic elevator arms from the machine coupling points by removing their locking bolts and connection pins.
- 12) Get back on the tractor and start the engine.
- 13) Drive it away carefully.

5 ADJUSTMENTS



Wear safety footwear, overalls, safety gloves and, if necessary, earplugs and a face mask during operations of maintenance, repair, movement or storage of the machine.

5.1 Working speed adjustment

Safe working speed depends on terrain condition, type of material to be cut, density, height of cut and the degree of shredding required.

In any case optimum speed ranges between 1-5 Km/h (0,62-3,10 Mph).

5.2 Adjusting the cutting height



Position the tractor on flat ground in order to prevent the application of lateral stress on the machine linkage system. Before performing this adjustment, stop the engine, apply the parking brake, switch off the power take-off and take out the ignition key.



Do not work or perform maintenance or repairs underneath the machine or its parts without supporting it securely on blocks or supports to prevent sudden falls that could cause serious injury or death.

Correct adjustment of the machine working height is important for:

- ▶ Performance of jobs in a workmanlike manner;
- ▶ Better performance of the machine and tractor;
- ▶ Considerable reduction of wear on the lateral runners (if any).

By adjusting the height of the support roller it is possible to vary the cutting height.



The flails must never touch the ground.

To perform adjustment, proceed as follows, on both sides of the flail head:

- ▶ Hold the shredder in a horizontal position, raised off the ground;
- ▶ Unscrew the screws (1).
- ▶ Align the roller (2) with one of the three adjusting holes (A,B,C) on the frame, depending on the degree of finishing that you want to obtain.
- ▶ Tighten the screws (1).

Height between roller and maximum cutting circumference								
A	mm	23	B	mm	47	C	mm	59
	in	0,90		in	1,85		in	2,32

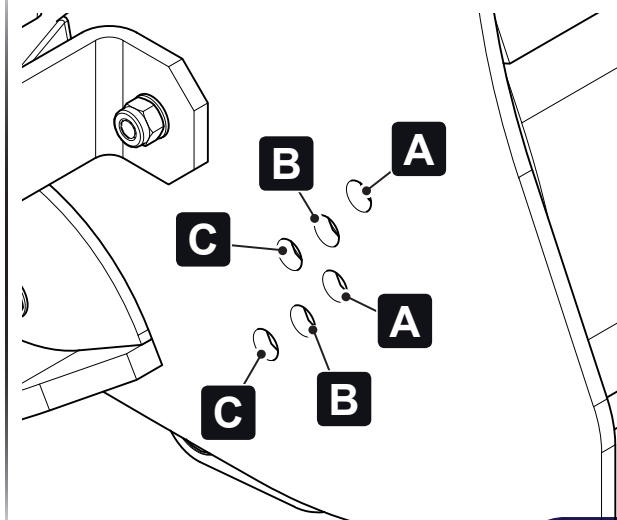
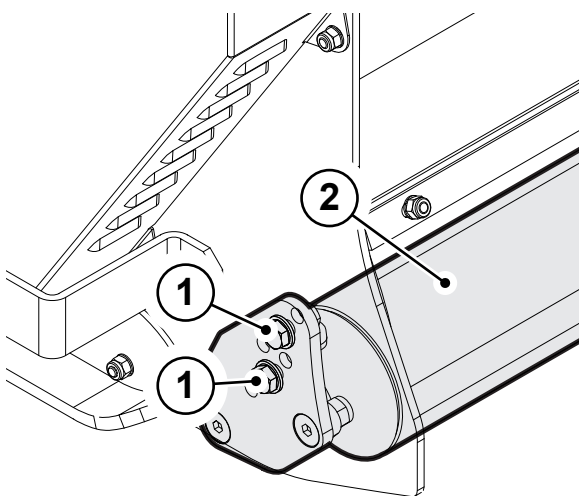

5.1

05-Regolazione altezza di taglio (ZT-ZTE)

To perform adjustment of the runners (if any), proceed as follows, on both sides of the flail head:

- 1) Hold the shredder in a horizontal position, raised off the ground;
- 2) Unscrew the screws (1), the nut (3) and relative washers;
- 3) Align one of the three holes (A,B,C) on the runner (2) with the hole on the frame depending on the degree of finishing you want to obtain;
- 4) Tighten the screws (1), the nut (3) and relative washers in the new position;
- 5) Position the runners on the supporting roller **A** high/high- **B** medium/medium - **C** low/low.

Adjustment of the runners should be made at the same time as adjustment of the supporting roller.



Take care during adjustment to prevent positioning the guards (4) too far from the ground so that during use of the machine they do not trap the solid bodies thrown out by the rotating flails.

05-Regolazione altezza di taglio (ZT-ZTE)

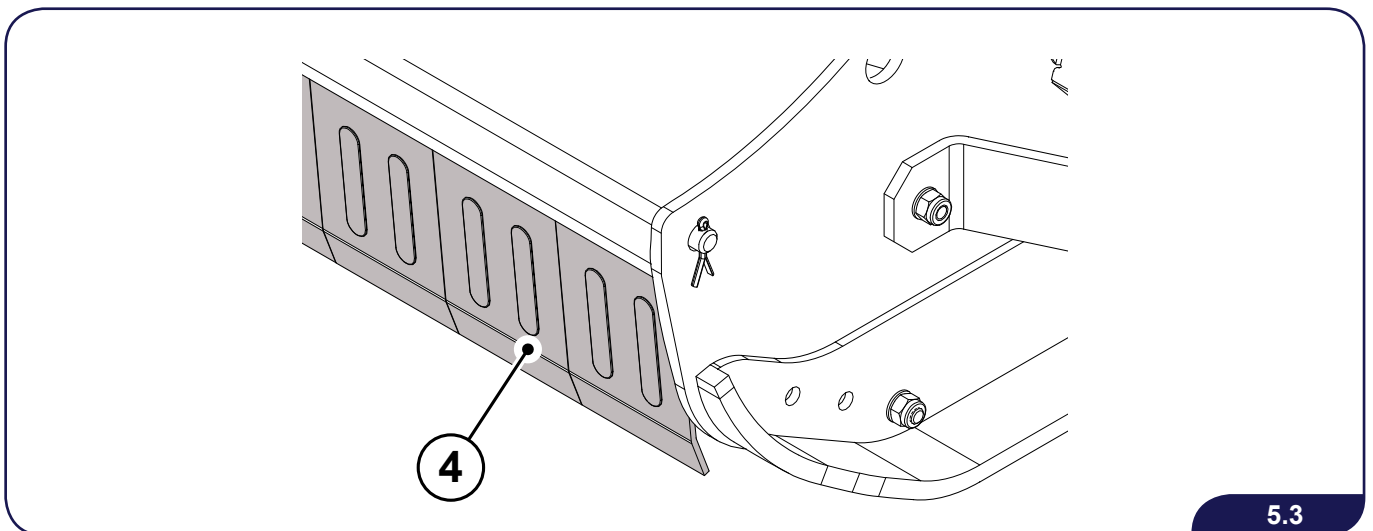
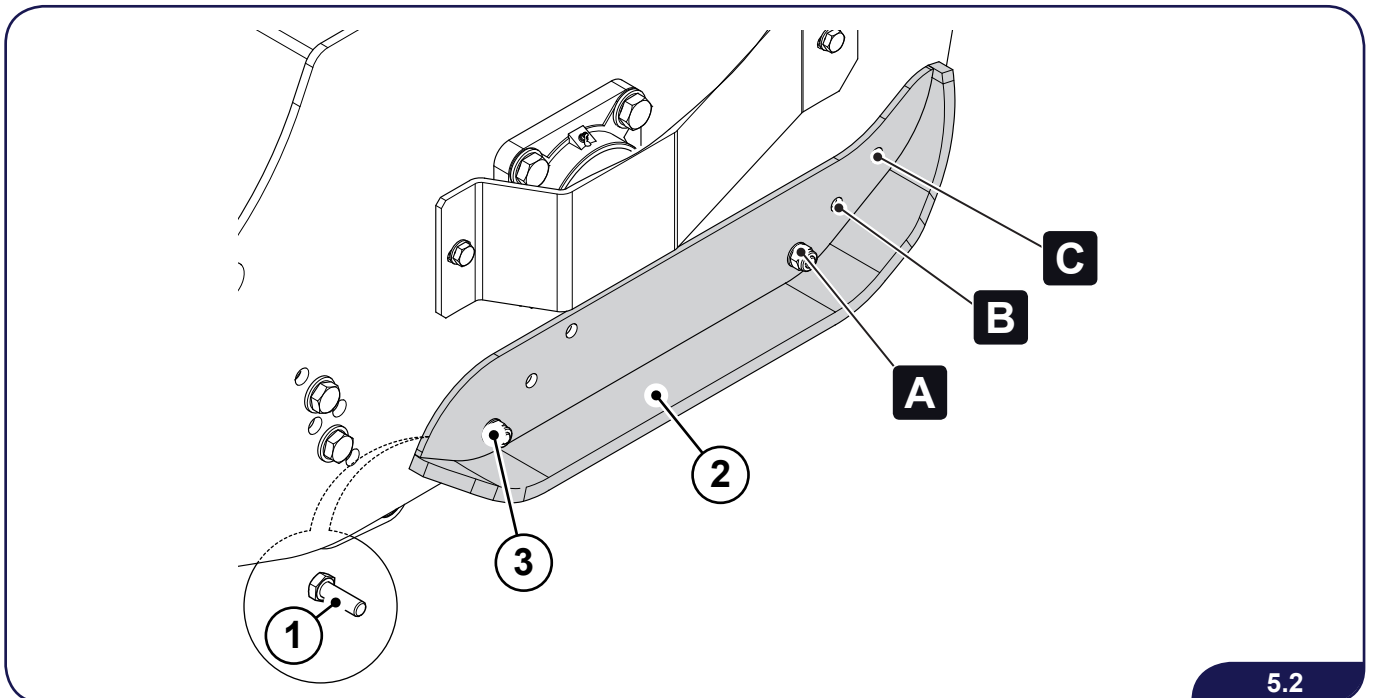

5.3 Adjusting the belt tension



Position the tractor on flat ground in order to prevent the application of lateral stress on the machine linkage system. Before performing this adjustment, stop the engine, apply the parking brake, switch off the power takeoff and take out the ignition key.

With internal gearbox:

- 1) Remove the belt protective casing (1).
- 2) Loosen the 4 screws (2) fastening the gearbox.
- 3) Adjust the stabilizer (3) to obtain a belt tension such that, with a pressure of **100 N** (measured with a dynamometer placed in the center of the top belt), a maximum bend of 15 mm is obtained.
- 4) When the belts are tightened correctly, fasten the 4 retaining screws (2) of the gearbox and replace the belt protection casing (1).

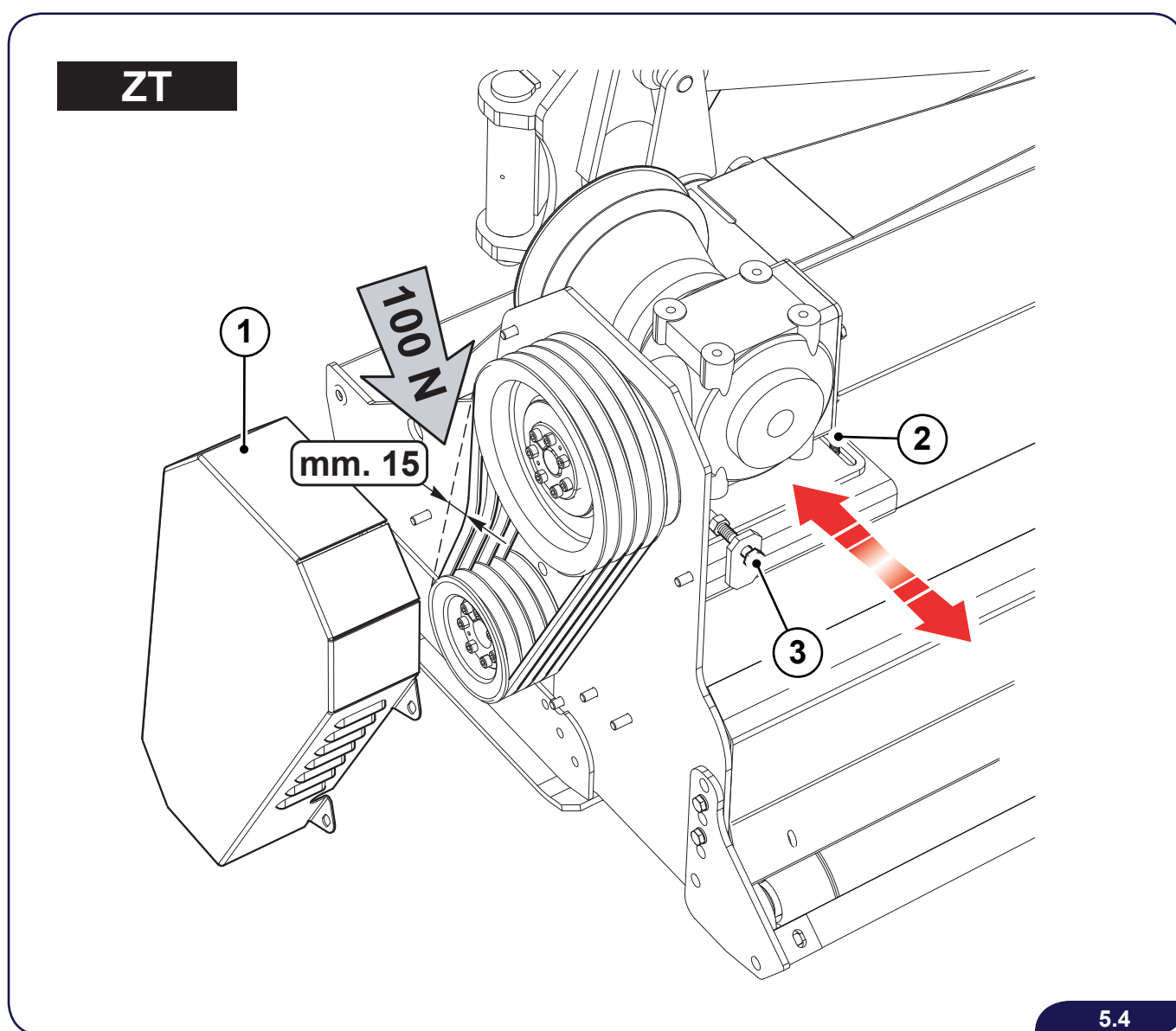

With external gearbox:

- 1) Remove the belt protective casings (1) and (2).
- 2) Loosen the 4 screws (3) fastening the gearbox.
- 3) Adjust the stabilizer (4), to obtain a belt tension such that, with a pressure of **100 N** (measured with a dynamometer placed in the center of the top belt), a maximum bend of 15 mm is obtained.
- 4) When the belts are tightened correctly, fasten the 4 retaining screws (2) of the gearbox and replace the belt protection casings (1 - 2).

05-Regolazione tensione cinghie (ZT-ZTE)

ZTE

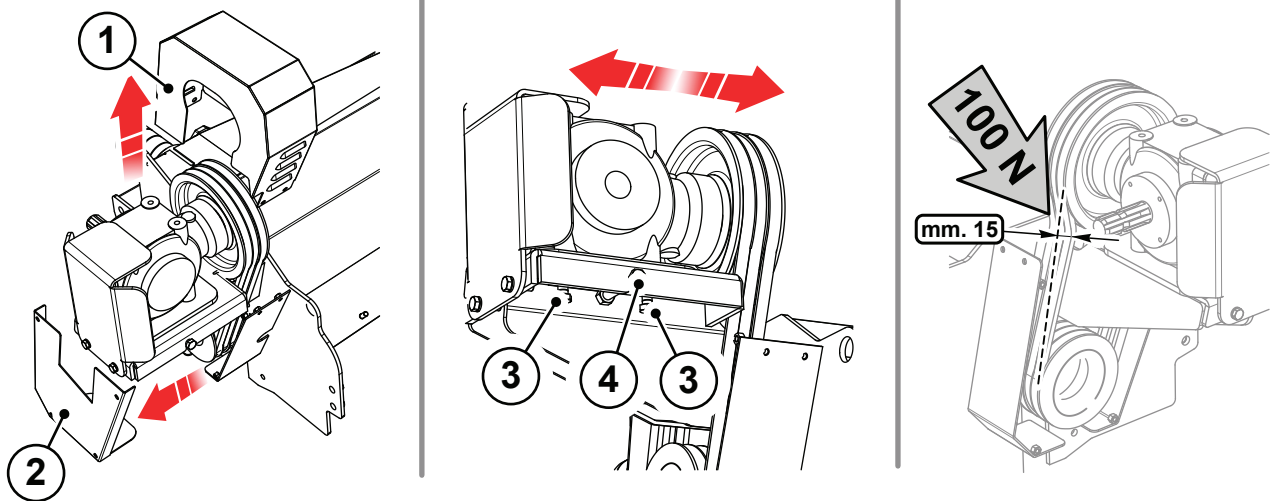

5.5



In addition to ensuring higher machine output, correct tightening keeps the belts from slipping (when they are too loose) or overheating (when they are too tight) that might otherwise cause breakage or premature wear.

Page left blank intentionally

05-Regolazione tensione cinghie (ZT-ZTE)

6 USE AND OPERATING RULES

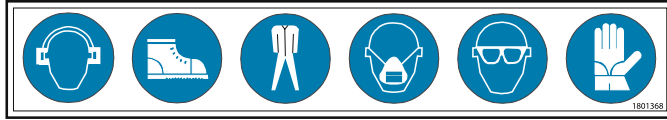

Wear safety footwear, overalls, safety gloves and, if necessary, earplugs and a face mask during operations of maintenance, repair, movement or storage of the machine.

6.1 Controls

The cab machine control levers must be installed inside the cab in an ergonomic position for the driver and fastened to a solid support on the tractor.
Under all circumstances, always keep all parts of the body inside the cab in order to reduce the risk of exposure to any external hazards.



WARNING

Before using the machine, learn to use the controls and their functions.

6.2 Positioning the machine during work stages

Proceed as follows to position the machine correctly during working stages:

- 1) Make sure there is sufficient space between the machine working range and any other equipment and/or property.
- 2) Open completely tap (1 - black handle - to release flail head) in position **A** and tap (2 - for release of the arms) in position **B** so the user can maneuver the machine.
- 3) Lower the tractor three point coupling elevator device until the rotor rests on the ground and the end tool is parallel to the ground.
- 4) Adjust the three point coupling to the position required and lock it in place.
- 5) Practice using the hydraulic control levers that maneuver the machine when it is working.



When working, do NOT touch the taps (1) and (2) to prevent damage to the machine.

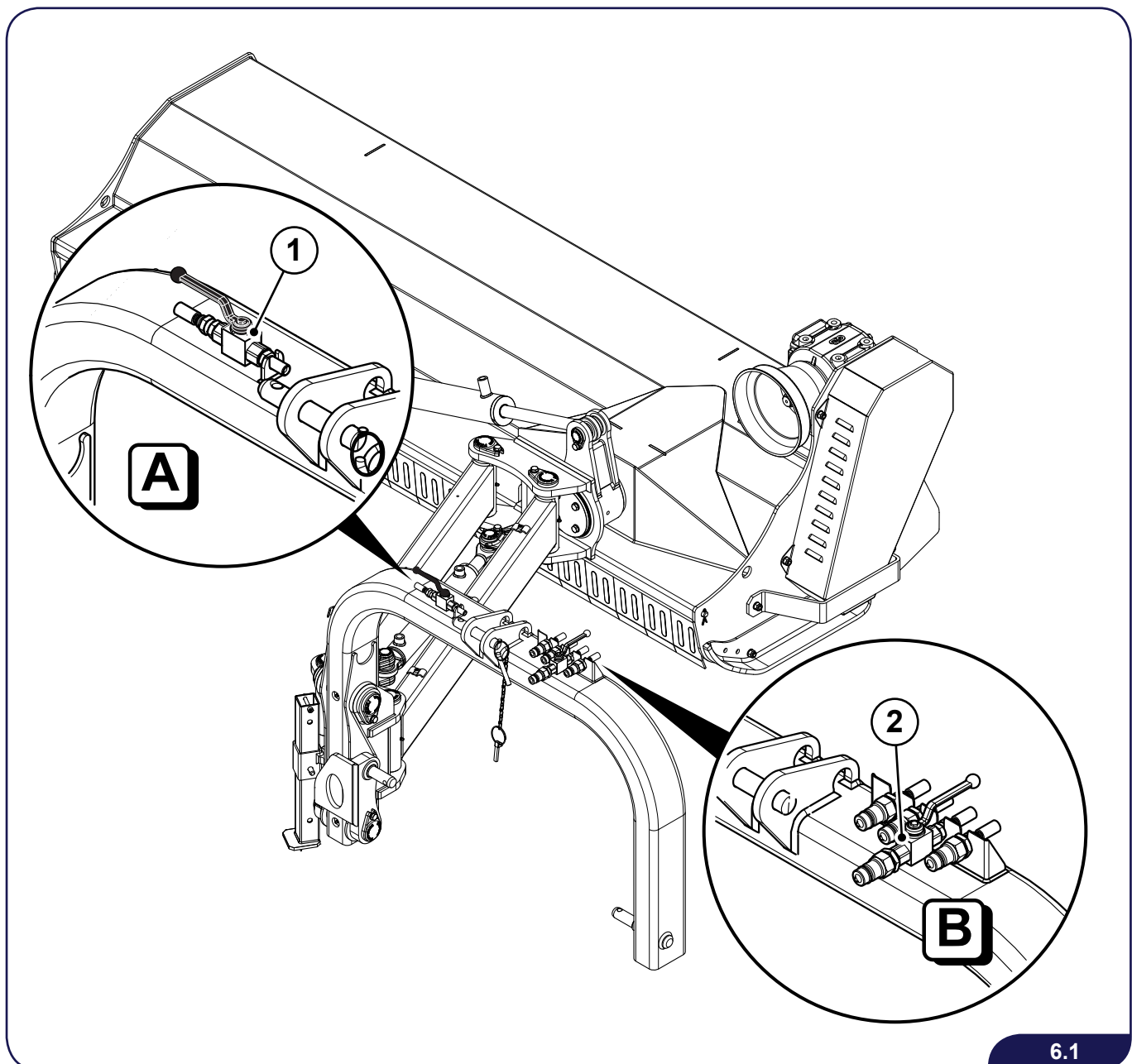

06-Posizionamento macchina ZT-ZTE

6.3 Startup

6.3.1 Preliminary checks

- ▶ Inspect the entire machine visually.
- ▶ Make sure all the screws are tightened.
- ▶ Make sure the guards are intact and in good condition.
- ▶ Check the oil level in the transmission unit.
- ▶ Check the rotor unit (condition of the shaft, the wear on the flails, etc.) and make sure that all the various elements are correctly tightened.
- ▶ Make sure that there are no leakages of oil from fittings or hoses.
- ▶ Check the correct operation of the electric system and light bar (if any).
- ▶ Make sure that the speed and rotation direction of the tractor power takeoff are as required by the machine (see the sticker on the gearbox).
- ▶ In case of application to a motor vehicle, check the rpm of the motor and availability of the necessary oil capacity to the hydraulic motor of the shredder.
- ▶ Make sure that no people and/or animals are present in a range of 50 meters (164' 1" ft).
- ▶ Grease all the machine parts.



IN CASE OF FAILURE TO FOLLOW THE ABOVE INSTRUCTIONS, THE USER WILL BE CONSIDERED LIABLE FOR ANY AND ALL CONSEQUENT CIVIL AND/OR CRIMINAL DAMAGE

6.3.2 Starting the machine

06-Avviamento



Never start the machine while the cutting flails are immersed in the vegetation to be cut.

- 1) Keep the tractor engine running at low rpm.
- 2) Apply force to the PTO lever slowly to start the rotor.
- 3) Once the PTO has been inserted at low tractor rpm, start gradually increasing the engine rpm until it reaches peak speed.
- 4) Wait until the flail shaft rotor reaches maximum speed before proceeding with mowing operations.



Whenever unusual noises and/or vibrations occur, immediately uncouple the PTO.

- 5) Accelerate the tractor slowly and smoothly until optimum working speed is reached (see Chapter 5).
- 6) Use all the controls gradually to keep the machine running smoothly.
- 7) Always run the machine at a forward speed equal to or slightly lower than optimum speed.



Do not allow the PTO to exceed the maximum speed admissible for the equipment used. Failure to respect this limit will endanger safety and could cause serious damage to the machine.



The machine is used with oil at temperatures over 30°C. Heat the oil with a hydraulic ram in position at the limit switch.

6.4 Work stages



During use, the shredder may give rise to the emission of dust. We recommend using a tractor that has filters on the cab ventilation system, or using suitable systems to protect the airways, such as dust masks or masks with a filter.

Travel a short distance and check whether the work obtained is satisfactory. If not, check the machine settings again (see Chapter 5).



WARNING

If the rotor should jam, before getting off the tractor and before performing any other operation, apply the parking brake and switch off the engine. Remove the ignition key and wait until all moving parts have come to a complete stop.



WARNING

In extending and closing the machine, raise it slightly off the ground to prevent damage to the structure.



WARNING

To prevent damage to the machine structure or arms during changes of direction and reversing, raise the machine off the ground and disengage the power take-off avoiding to work with the arm and/or the shredding flail head.



WARNING

Do not let the flails rotate when the head is raised off the ground. The possible launch of objects by the flails could cause serious injury or death.

6.5 Stopping

Before stopping the tractor:

- 1) Close the arms and lower the flail head to the ground;
- 2) Disengage the rotor drive and wait till the rotor has come to a complete stop (approx. 30 sec.);
- 3) Turn off the tractor engine, remove the ignition key out and apply the parking brake;
- 4) If the ground slopes steeply, fit wedges under the tractor wheels to block it;
- 5) Make sure all moving parts have ceased rotation before switching off the tractor engine or moving the tractor (with the machine not in function).

6.6 Transport position

For road transport, the user must:

- ▶ Place the head perpendicular to the ground.
- ▶ Close tap (1 - black handle), turning the lever to position "A", to block the flail head in the correct position and prevent its descent;
- ▶ Use the translation ram to position the shredder as closely as possible to the tractor.
- ▶ Close tap (2), turning the lever to position "B", to prevent the machine from opening when driving on the road.
- ▶ Attach appropriate signs indicating the overall dimensions and size of the machine.
- ▶ Never raise the machine too high: make sure that the PTO shaft never exceeds a 30° angle with the power take-off uncoupled as this could risk damaging the PTO shaft.
- ▶ Install a light bar on the rear if the machine covers the tractor's tail lights.
- ▶ Check that the hydraulic elevator levers are blocked so that the machine will not descend during transport.
- ▶ Observe all the road transport requirements.
- ▶ See paragraph 2.2 – **Safety rules concerning road traffic** in this manual.

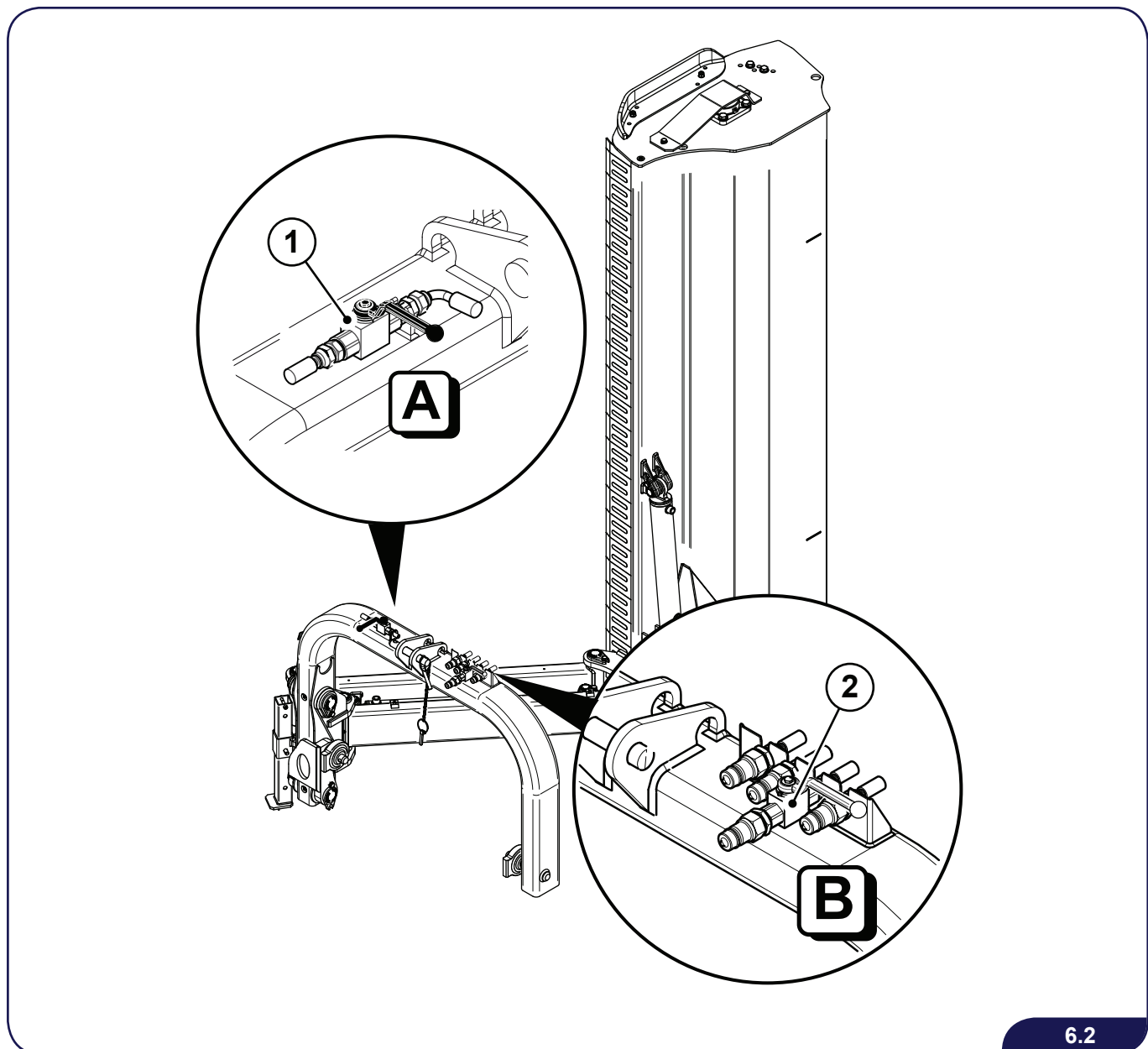

06-Posizione di trasporto (ZT-ZTE)

**WARNING**

Never engage the machine flail rotor with the tractor PTO when the unit is in the transport position.

Drive at adequate speed above all with equipment that could be subject to severe tilting at the front and rear or when there is heavy traffic, or the road is steep or winding.

When going out onto the road after working, take care to clean the tires or other working parts, so as not to soil the road surface with earth or other material.

**WARNING**

During transport reduce speed especially on bumpy roads.

The weight of the machine could make it difficult to drive and cause damage to the machine.

During road transport the power take-off must be disconnected.

Page left blank intentionally

06-Posizione di trasporto (ZT-ZTE)

7 ROUTINE MAINTENANCE



Wear safety footwear, overalls, safety gloves and, if necessary, earplugs and a face mask during operations of maintenance, repair, movement or storage of the machine.

7.1 General information

Hereafter we indicate the criteria for routine maintenance of the machine, based on our experience and the recommendations we have received from our clients.

These criteria are not exhaustive and can therefore be added to through the collaboration of our clients.

Good routine maintenance will reduce the working costs of the machine and enable you to make the most of its potential. For specific repair or maintenance operations where it may be necessary to hoist the machine off the ground or turn it over, use proper equipment, elevators or winches suitable for this purpose (see Chapter 4).

Always contact authorized dealers and workshops.

For the replacement of parts, use only original replacements furnished by the manufacturer or authorized dealerships.

07-MANUTENZIONE ORDINARIA



Before you perform any type of maintenance:

- 1) Wait until all moving parts have come to a complete stop;
- 2) Lower the machine to the ground;
- 3) Disconnect the power take-off;
- 4) Switch off the tractor engine (or vehicle);
- 5) Apply the parking brake;
- 6) Remove the ignition key;
- 7) Get off the tractor to check the extent of the problem;
- 8) Wait for the oil and hot surfaces to cool;
- 9) Proceed with any repairs required on the machine.

7.2 Checklist

The Checklist helps you plan all the maintenance operations and monitor their frequency to ensure correct routine maintenance of the machine.

The manufacturer recommends keeping the original document attached to the instruction manual, and creating personal copies for every authorized technician, to make a note of the interventions carried out on the machine.

7.2.1 Every 8 working hours or every day

- ▶ Check for the tightening of screws and nuts
- ▶ Check for the wear and condition of flails
- ▶ Make sure the safety guards are intact and in good working order
- ▶ Grease the pins, bearings, spiders and PTO shaft telescopic barrel, etc.

7.3 Oil table

The following table lists the types of oil to use when topping up.

TAB 5	OIL QUANTITY IN THE GEAR BOX	TYPE	CLASSIFICATION
		BLASIA 220	ISO VG 220
		liters	gallons
		1,3	0,34

07-Tabella oli

7.4 Greasing

LUBRICANT	
TYPE	CLASSIFICATION
AGIP GR MU EP/2	SAE90

- ▶ Use a portable grease gun for all greasing.
- ▶ Wipe the grease nozzle with a clean dry cloth, to avoid injecting dirt and grit.
- ▶ Under particularly taxing work conditions, we recommend performing greasing more frequently than the average, every 8 hours, usually adopted.
- ▶ Replace or repair damaged or broken nozzles immediately.
- ▶ If the nozzles will not take grease, remove and clean them thoroughly. Also clean the lubricant input opening. Replace the nozzle if necessary.
- ▶ In the event of prolonged inactivity, repeat these operations before using the machine again.

07-Ingrassaggio

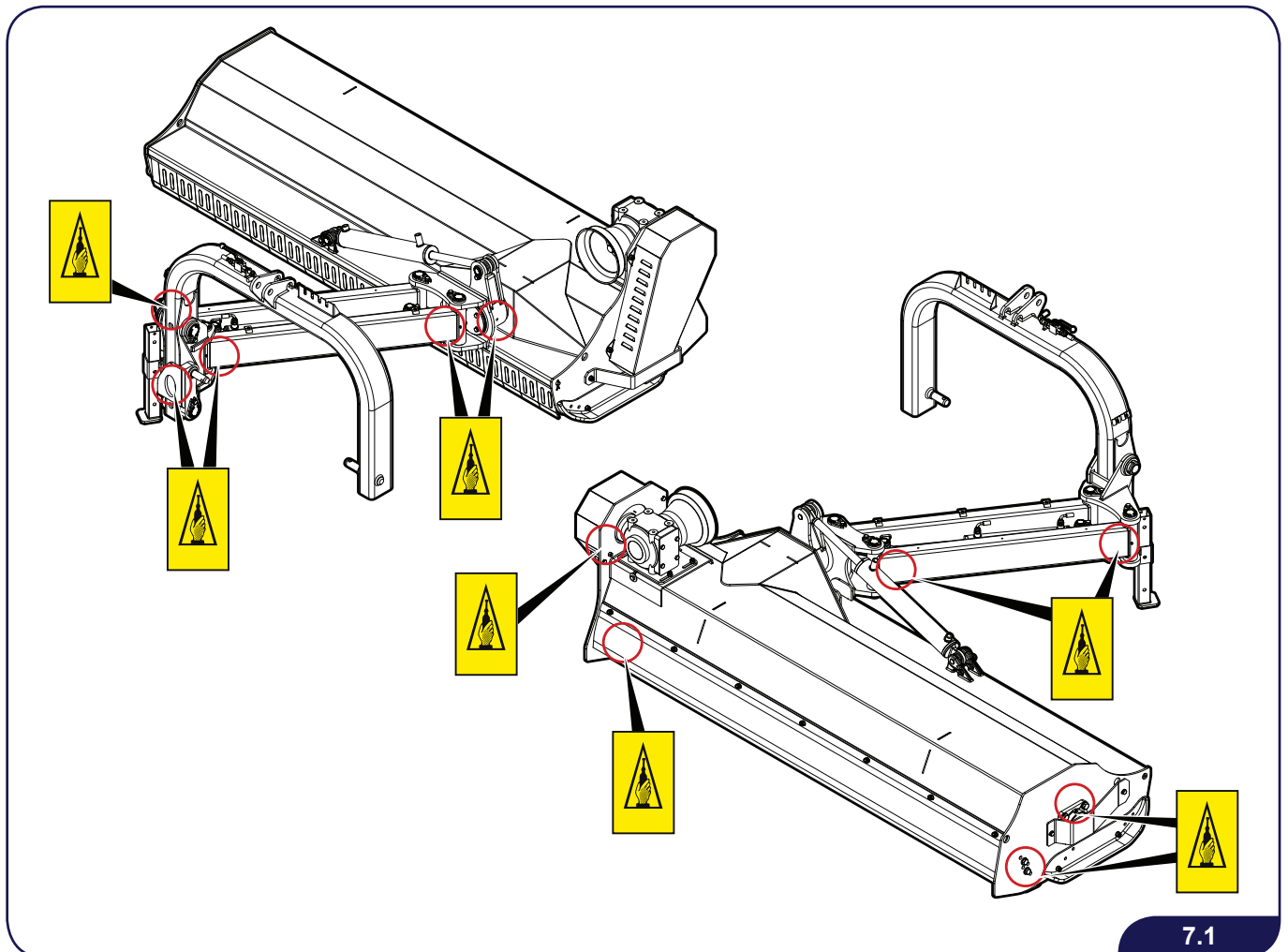

INCREASE THE FREQUENCY OF ROUTINE MAINTENANCE IF THE MACHINE IS USED UNDER PARTICULARLY TAXING WORK CONDITIONS.

7.5 Belt state



Check for correct belt tension every 50 hours.
Replace the belts every 500 hours.

New belts

If the belts are new, check the tension the first time after 4 hours of work to ascertain the degree of breaking in and tension.

Used belts

If the belts are broken in or have been used for more than 24 hours, check for wear and, if necessary, adjust to the proper tension (see Chapter 5).

7.6 Hydraulic hose couplings

Check correct fastening of hydraulic hose couplings (TAB 2).

TAB 2		
Type of threading	Tightening torque MIN N.m	Tightening torque MAX N.m
1/8	12	14
1/4	14	16
3/8	25	28
1/2	45	60
5/8	55	70
3/4	90	110
1"	120	140
1" 1/4	170	190
1" 1/2	200	245



Table of tightening torques for cylindrical threading type GAS UNI ISO 228 1 83 - BSPP

07-Serraggio viti



TAB 3	
Type of threading	Tightening torque N.m
M12 x 1.5	20
M14 x 1.5	38
M16 x 1.5	45
M18 x 1.5	51
M20 x 1.5	58
M22 x 1.5	74
M24 x 1.5	74
M26 x 1.5	105
M30 x 2	135
M36 x 2	166
M45 x 2	290
M52 x 2	330







Table of tightening torques for metrical threading type UNI 5541 - 65 UNI 5542 - 66

7.7 Bolt tightening

Make sure the bolts are correctly fastened (TAB 3).

TAB 3															
STANDARD DIN 267		new ►		4.8		5.8		6.8		8.8		10.9		12.9	
 mm	 mm	Pitch		Pitch		Pitch		Pitch		Pitch		Pitch		Pitch	
		● mm	○ mm	● Nm	○ Nm	● Nm	○ Nm	● Nm	○ Nm	● Nm	○ Nm	● Nm	○ Nm	● Nm	○ Nm
M2	4	0,4	-	0,2	-	0,2	-	0,2	-	0,3	-	0,4	-	0,5	-
				0,2	-	0,2	-	0,3	-	0,4	-	0,5	-	0,6	-
M2.5	5	0,45	-	0,3	-	0,4	-	0,5	-	0,6	-	0,9	-	1,1	-
				0,4	-	0,5	-	0,6	-	0,8	-	1,1	-	1,3	-
M3	5,5	0,5	-	0,5	-	0,7	-	0,8	-	1,1	-	1,5	-	1,8	-
				0,6	-	0,8	-	1,0	-	1,3	-	1,9	-	2,3	-
M3.5	6	0,6	-	0,8	-	1,1	-	1,3	-	1,7	-	2,4	-	2,8	-
				1,0	-	1,3	-	1,5	-	2,1	-	2,9	-	3,5	-
M4	7	0,7	-	1,3	-	1,6	-	1,9	-	2,5	-	3,5	-	4,2	-
				1,5	-	1,9	-	2,3	-	3,1	-	4,3	-	5,2	-
M5	8	0,8	-	2,5	-	3,1	-	3,7	-	4,9	-	6,9	-	8,3	-
				3,0	-	3,8	-	4,5	-	6,0	-	8,5	-	10	-
M6	10	1,0	-	4,2	-	5,3	-	6,4	-	8,5	-	12	-	14	-
				5,2	-	6,5	-	7,8	-	10	-	15	-	18	-
M7	11	1,0	-	7,0	-	8,7	-	10	-	14	-	20	-	24	-
				8,6	-	11	-	13	-	17	-	24	-	29	-
M8	13	1,25	1,0	10	11	13	14	15	16	20	22	29	31	34	37
				13	14	16	17	19	20	25	27	35	38	42	46
M10	17	1,5	1,25	20	21	25	26	30	32	40	42	57	59	68	71
				25	26	31	33	37	39	50	53	70	74	84	89
M12	19	1,75	1,5	34	36	43	45	52	54	69	72	97	101	116	121
				42	45	53	56	64	67	85	89	119	125	143	150
M14	22	2,0	1,5	55	59	68	74	82	89	110	118	154	166	185	199
				68	74	84	92	101	111	135	148	190	208	228	250
M16	24	2,0	1,5	85	90	106	112	128	135	128	180	240	253	287	303
				106	113	132	141	159	170	212	226	298	318	357	382
M18	27	2,5	2,0	118	124	147	155	176	186	235	248	330	349	397	419
				145	155	182	194	218	233	290	310	402	436	490	523
M20	30	2,5	2,0	166	174	208	217	249	261	332	347	467	489	561	586
				206	218	258	273	310	327	413	436	580	614	697	736
M22	34	2,5	2,0	227	237	284	296	341	355	454	474	639	666	767	799
				284	299	355	373	426	448	568	597	798	840	958	1.008
M24	36	3,0	2,0	287	309	359	386	431	463	574	617	808	868	969	1.041
				357	390	446	488	535	586	714	781	1.004	1.098	1.204	1.317
M27	41	3,0	2,0	420	448	525	561	630	673	840	897	1.181	1.261	1.418	1.513
				525	570	656	712	788	855	1.050	1.139	1.477	1.602	1.772	1.923
M30	46	3,5	2,0	573	624	716	780	859	936	1.146	1.248	1.611	1.754	1.933	2.105
				714	795	893	994	1.072	1.193	1.429	1.590	2.009	2.236	2.411	2.648

07-Serraggio viti

SYMBOL	SIGNIFICANCE
	Screw
	Hex head
	Large
	Fine

The torque values shown in table 3 correspond to 80% of the yield stress limit. Every field contains two values, the first of which refers to a friction coefficient of 0.10 and the second to a coefficient of 0.14. For our applications we recommend referring to the values corresponding to the coefficient of 0.14.

The torque should be considered for orientation purposes and may vary considerably in relation to the type of joint (rigid, semirigid, elastic, etc.); the material on which the screws are tightened; the length of the screws; the type of screwdriver used to tighten them (such as impulse, friction, continuous torque, etc.); the conditions of finishing of the thread; etc.

If the joint is made with nuts or selflocking rings, the torque value should be increased by about 15%.

7.8 *First use or resumption of use after prolonged disuse*

Before using the machine for the first time or after a long period of disuse:

- ▶ Make sure the machine does not show any damage;
- ▶ Check that all the mechanical parts are in good conditions and free of rust;
- ▶ Check the level of liquid in the hydraulic service system;
- ▶ Check the state of wear of the flails;
- ▶ Make sure the light bar and electrical system are working correctly;
- ▶ Clean the moving parts to remove any protective grease;
- ▶ Thoroughly grease all moving parts;
- ▶ Make sure that there are no leakages of oil from fittings or hoses;
- ▶ Check that all the guards are positioned correctly;
- ▶ Make sure the system is functioning properly;
- ▶ Protect all the electrical connections with anti-oxidant.

7.9 Parking or storage

When the machine will not be used for a prolonged period, proceed as follows to keep the machine in good conditions and protect it from dust and rust.

- ▶ Detach the machine from the tractor (see Chapter 4).
- ▶ Wash the machine thoroughly to remove any debris, residues, dirt or mud.
- ▶ Make an overall visual inspection of the machine to check for any structural damage and/or deep abrasions on the paint. Touch up any scratches and dents in the body to prevent rust from forming. Replace and/or repair any damaged parts.
- ▶ Make sure the flails and supports are intact and not worn. If they show wear, replace them.
- ▶ Check the conditions of the safety guards on the machine. Replace and/or repair any damaged guards.
- ▶ Inspect all hydraulic hoses, couplings and hitches. Tighten all the couplings. Replace any damaged, abraded or cut hoses, or if the crimping at the connector is damaged.
- ▶ Make sure the safety decals are intact, legible and correctly positioned. Replace any safety decals that have been damaged and/or are illegible.
- ▶ If any damage or abrasions are found, make the necessary repairs.
- ▶ Grease all the mechanical parts, the tightening pins, the coupling head to the PTO shaft. Make sure the grease penetrates correctly in all cavities, to eliminate any residual wetness left after washing the machine. This will protect the bearing gaskets.
- ▶ Store the machine in an area sheltered from atmospheric agents and preferably far from all human activities.
- ▶ Store the machine in a flat, dry area.
- ▶ Place the frame on special supports to improve stability.
- ▶ Cover the machine with a tarpaulin, fastening it appropriately.



Do not dispose of the used oil carelessly. Oil is a special waste and must be delivered to specific collection centers, in accordance with the laws in force. Contact the used oil collection center nearest you.

We recommend closing the tap of the suspension accumulator (LFA) so as to prevent it from discharging while parked.



Clean the electronic control unit and its wiring if they are soiled or wet:

- 1) Unplug the control unit;**
- 2) Clean with a jet of compressed air;**
- 3) Spray with special rustproofing compound for electric contracts.**
- 4) Take care to apply some silicone (for electrical systems) to seal the screws on the type DIN electric parts that may have been removed for maintenance.**

Page left blank intentionally

07-Messa in parcheggio o deposito

8 EXTRAORDINARY MAINTENANCE

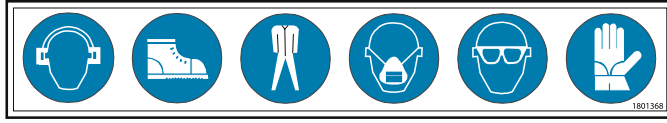

Wear safety footwear, overalls, safety gloves and, if necessary, earplugs and a face mask during operations of maintenance, repair, movement or storage of the machine.



WARNING

Before you perform any type of maintenance:

- 1) Wait until all moving parts have come to a complete stop;
- 2) Lower the machine to the ground;
- 3) Disconnect the power take-off;
- 4) Switch off the tractor engine (or vehicle);
- 5) Apply the parking brake;
- 6) Remove the ignition key;
- 7) Get off the tractor to check the extent of the problem;
- 8) Wait for the oil and hot surfaces to cool;
- 9) Proceed with any repairs required on the machine.

8.1 Hose replacement



Any maintenance on the hydraulic system must be performed by specially trained personnel.

WARNING

- ▶ Before working on the hydraulic system, exhaust all pressure, working with the engine off and turning all control levers.
- ▶ Take particular care during cleaning: dust, chips or other can cause irreparable damage to the hydraulic parts.
- ▶ Replace any damaged hoses with original replacements. When fastening, take care not to twist the hoses and keep their complete movement in mind.
- ▶ Take care not to spill any oil during hose replacement. Collect the oil in containers and dispose of it at special waste disposal centers.



Check the hydraulic hoses for wear every day. Replace them when they show any abrasion or cracking.

WARNING



Replace the hydraulic hoses at least every 6 years.

WARNING



Remember to open the oil suction cocks after replacing the hydraulic pipes. The pump only needs to rotate "dry" for a few seconds to be irreparably damaged.

CAUTION



Check the conditions of the filters regularly and monitor the hydraulic oil level in the tank to prevent contamination, overheating or other damage to the hydraulic system.

CAUTION

8.2 Belt replacement

With internal gearbox:

- 1) Remove the belt protective casing (1);
- 2) Loosen the 3 screws (2) fastening the plate;
- 3) Loosen the belt tightener (3);
- 4) The pulley position can be adjusted to reduce belt tension;
- 5) Remove the belts (4) from the respective pulley races and replace them with new ones;
- 6) After replacing the belts (4), adjust them as indicated in Chapter 5;
- 7) Reassemble the belt cover case (1).

ZT

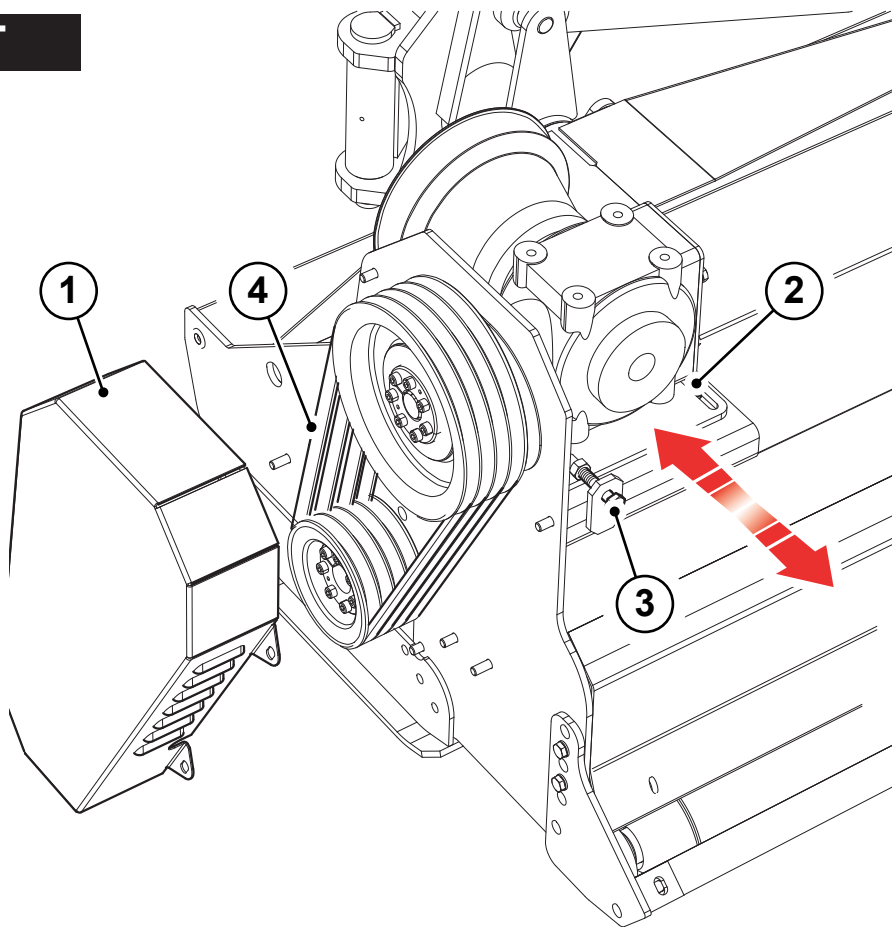

8.1

08-Sostituzione delle cinghie (ZMT-ZMTE-ZT-ZTE)



Replace all the belts in the set even if only one is deteriorated.

With external gearbox:

- 1) Remove the belt protective casings (1) and (2);
- 2) Loosen the 3 screws (3) fastening the plate;
- 3) Loosen the belt tightener (4);
- 4) The pulley position can be adjusted to reduce belt tension;
- 5) Remove the belts (5) from the respective pulley races and replace them with new ones;
- 6) After replacing the belts (5), adjust them as indicated in Chapter 5;
- 7) Reassemble the belt cover cases (1) and (2);

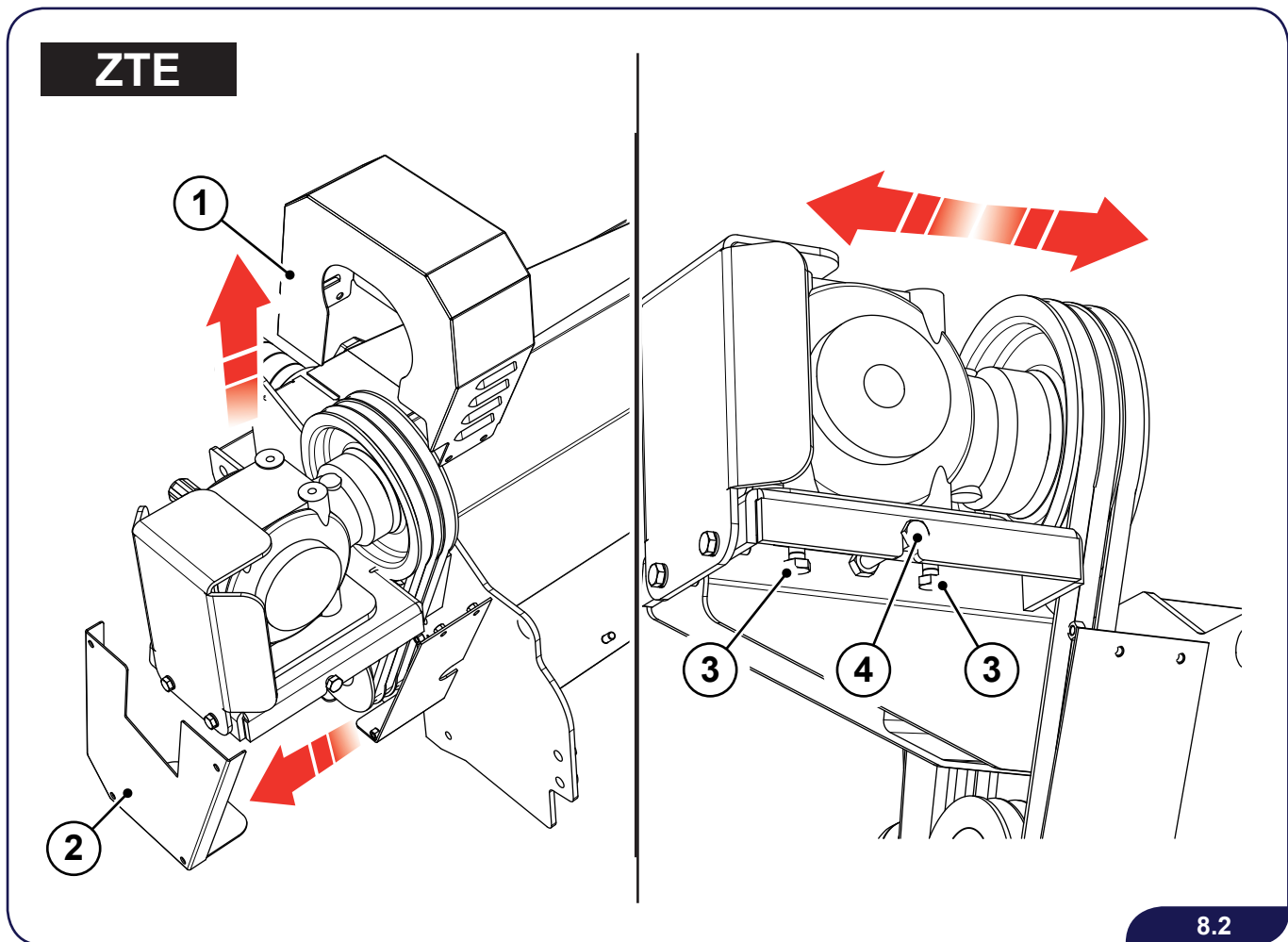

08-Sostituzione delle cinghie (ZMT-ZMTE-ZT-ZTE)



CAUTION

Replace all the belts in the set even if only one is deteriorated.

8.3 Pulley replacement

The pulleys are fastened to the respective shafts by means of a keying device (1).

Proceed as follows to disassemble the pulleys:

- 1) Loosen the screws (2) with the special wrench;
- 2) Remove the screws (2) and fit them in the threaded holes (3), tightening uniformly.
- 3) After a few turns of the screws, the pulley can be removed from the shaft easily.

Proceed as follows to replace the pulleys:

- 1) Fit the keying device (1) in the pulley hole;
- 2) Couple the entire unit to the shaft after first checking the correct position of the pulley;
- 3) Uniformly tighten the screws (2) using the corresponding torque wrench $M=35\text{Nm}$.

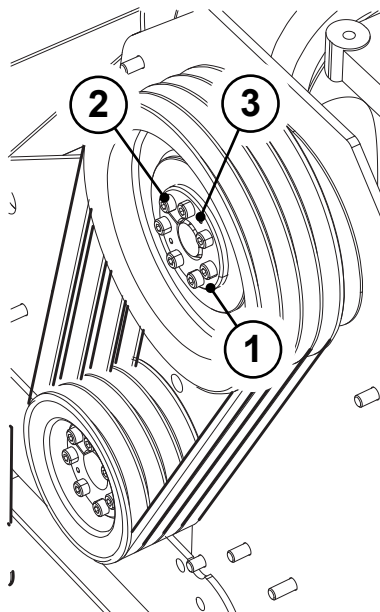

08-Sostituzione delle pulegge

8.3



**Inspect all the belts visually before reassembling them.
If you notice any deterioration, even of a single belt, replace all of them.**

8.4 *Security pin replacement*

Perform this operation with an elevator or winch to prevent unfastened parts from falling or causing dangerous unbalancing.

When replacing pins, clean and grease their housings.

8.5 Guards



Always check the general conditions of the guards: make sure they are intact, securely fastened, etc.

Guards that are bent, damaged or not fastened correctly cannot guarantee the operating safety for which they were designed.

IN CASE OF FAILURE TO FOLLOW THE ABOVE INSTRUCTIONS, THE USER WILL BE CONSIDERED LIABLE FOR ANY AND ALL CONSEQUENT CIVIL AND/OR CRIMINAL DAMAGE

8.5.1 Flaps

At the end of every working day, check the perfect efficiency of the flaps, making sure that they are intact and free to move as required.

Wash the machine in the zones clogged with mud or dirt to ensure the mobility of the flaps (if necessary, spray with lubricants).

To replace damaged flaps, proceed as follows:

- 1) Remove the split pin (2) and remove the fastening rod ((1));
- 2) Replace the damaged flaps (3) ;
- 3) Re-assemble the fastening rod (1);
- 4) Unscrew the nuts (7) and the washers (6);
- 5) Remove the fastening rod (5);
- 6) Replace any damaged guards (4);
- 7) Reposition the fastening rod (5);
- 8) Unscrew the nuts (7) and the washers (6);

08-Protezioni (ZT-ZTE)

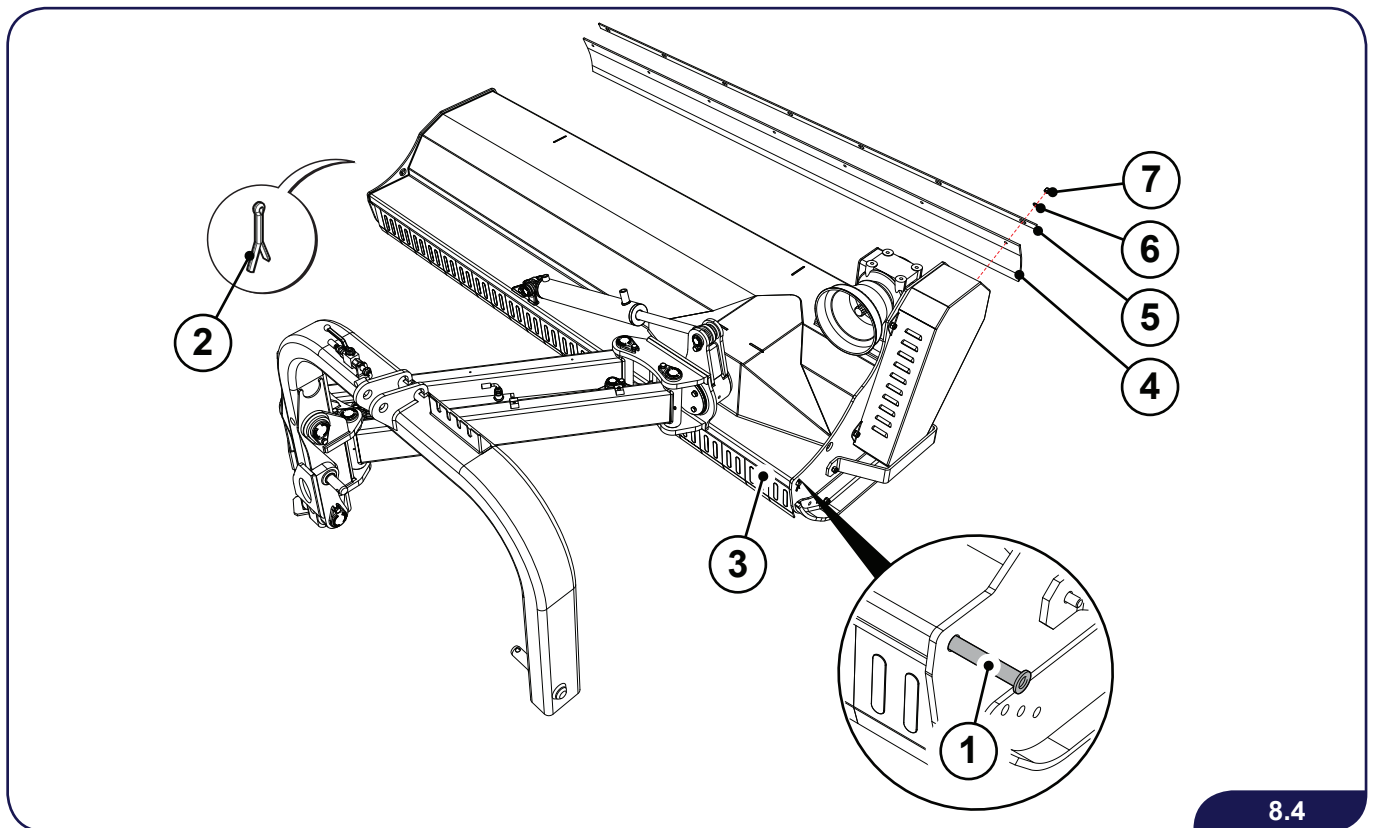

8.4



Use only original spare parts.

8.6 Rotor

The rotor shaft has already been electronically balanced. If a flail has to be replaced, it is advisable to replace the whole set. Installation of non-original flails may cause vibrations or breakage of the roller bearings.



To replace damaged parts or flails, contact FERRI's specialized personnel or an authorized dealer.



If you notice any irregularities or strange noises after changing the flails, contact FERRI immediately.

8.7 Flails replacement

If the flails are excessively worn, replace them. In case of partial breakage of the flail, replace it and also the one directly opposite it to maintain a perfect balance.

To replace the flails, hoist the machine and work under it.

Hoist the flail head using the tractor elevator and support it to prevent involuntary descent of the elevator.



Do not rely on the holding power of the hydraulic elevator: fit trestles or mechanical struts between the machine and the ground, to prevent accidental descent of the head.

Make sure that the tractor PTO is disengaged, set the parking brake, switch off the engine and remove the key from the dashboard.

08-Sostituzione degli utensili

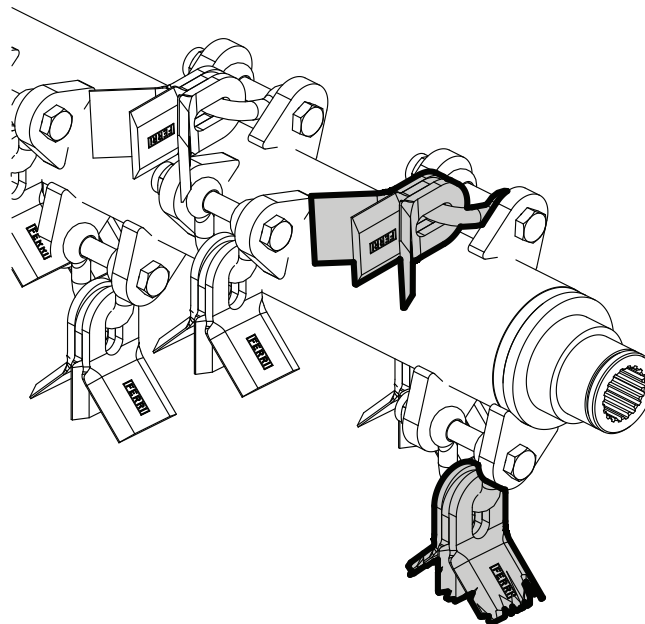

When replacing the flails, DO NOT REMOVE THE BALANCING WEIGHTS from their original position.



If you notice any irregularities or strange noises after changing the flails, contact FERRI immediately.



Replace any bent or broken flails with new ones. For safety reasons, do not try to straighten bent flails or perform welds on them, as that would alter their strength.



Use only original FERRI parts for replacement.

Page left blank intentionally

08-Sostituzione degli utensili

9 TROUBLESHOOTING TABLE



Wear safety footwear, overalls, safety gloves and, if necessary, earplugs and a face mask during operations of maintenance, repair, movement or storage of the machine.

9.1 *Troubleshooting table*

The maintenance operations authorized by FERRI srl are indicated in Chapter 7 – “ORDINARY MAINTENANCE”. The contents of this chapter are not exhaustive, but attempt to provide information on the most common problems to assist specialized service experts in finding the cause.

The information provided under “REMEDIES” in the tables below **DOES NOT AUTHORIZE** repairs if they could interfere with safety.



WARNING

To replace damaged parts or flails, contact FERRI's specialized personnel or an authorized dealer.

9.1.1 *General*

The following information refers to common problems that occur on all the machines (flail heads, shredders, flail hedge mowers, etc.) as well as problems typical of specific types of machine.

PROBLEMS	PROBABLE CAUSE	REMEDIES
Irregular cut	Worn, bent or broken flails	Replace
	The machine is not correctly positioned parallel to the ground	Adjust the stabilizers connected to the tractor or the flail head rotation hydraulic ram
	Difficulty in unloading chopped material caused by excessive forward speed	Reduce forward speed
	The rotor turns at insufficient rpm	Check the rpm on the tractor PTO and adjust it to the number of rpm required by the machine (see the machine technical data)
	Damaged motor and/or pump	Repair or replace the motor or pump
	Slipping of the belts on the pulleys	Adjust belt tension

PROBLEMS	PROBABLE CAUSE	REMEDIES
Cutting height not correct	Roller position not correct	Adjust the roller to reduce or increase cutting height
Excessive machine operating noise	Loose bolts	Check and correct, tightening any screws and nuts where necessary
	Machine shows cracks or initial signs of breakage	Have the frame repaired at an authorized Ferri workshop. Check to see if there are any unbalanced moving parts and correct the defect
	Worn bearings	Replace
Gearbox noise	Low oil level	Top up the oil
	Worn or damaged gears	Repair or replace
	Worn or damaged bearings	Repair or replace
Premature flail wear	Flails touch the ground or work on rocky soil	Adjust height of cut
Breakage of roller bearings	Violent impact on the ground when the machine is lowered	Lower it gently
	Bearings dirty or need greasing	Clean and/or grease
Flail-holder shaft speed decreases	The hydraulic circuit is losing pressure	Check the efficiency of the pump and hydraulic motor. Check the hydraulic system pressure settings. These checks must be performed at specialized workshops

PROBLEMS	PROBABLE CAUSE	REMEDIES
Vibrations	Broken, worn or missing flails	Replace the flails
	Unbalanced flail holder shaft	Check rotor balancing and have repairs or replacements made in authorized Ferri workshops
	Worn flail holder shaft bearings	Have them replaced in specialized workshops
	Unbalanced moving parts	Identify the part responsible for the problem (unbalanced rotor, defective bearing, broken or missing flail, etc.) and have it repaired or replaced at authorized Ferri workshops
	Couplings at the two ends of the PTO shaft out of parallel alignment	Check the coupling of the machine to the tractor and check the adjustments
	Blocked flails	Stop the machine and free them
	Plant waste or foreign objects wrapped around the rotor shaft and/or the cutting flails or encrustation visible on the cutting tools or supports	Remove waste or foreign objects or replace cutting tools (in this case, always replace opposite pairs). Clean the rotor and the cutting flails
	Loose bolts	Check and correct, tightening any screws and nuts where necessary
	Rotor flanges not perfectly adherent to the walls of the machine. Deformed machine side panels	Check the conditions of the machine side panels and repair if necessary. Check the correct assembly of the flanges and the tightening of the screws

PROBLEMS	PROBABLE CAUSE	REMEDIES
Hydraulic oil overheating (over 80°C)	Excessive material to shred	Reduce forward speed
	Hydraulic system requires checking	Have it checked in an authorized Ferri workshop, particularly as regards the conditions of the filter and hydraulic hoses, valve settings, etc.
	Malfunctioning heat exchanger	Check the electric system for the heat exchanger and thermostat
	Excessive rotor rpm	Check the tractor PTO rpm and, if necessary, reduce the rpm as prescribed for the machine in use
Excessive backlash in the arms and joints	Worn pins or bushes	Replace
Flail-holder rotor speed is lower than required	Loose belts	Restore proper belt tension
The flail head shifts backward during working	Improper adjustment of the max. pressure valve setting	Have valve pressure setting calibrated by an authorized Ferri workshop
	Leakage of oil from hydraulic ram	Check the hydraulic ram oil seals and sealing in general and have repairs or replacements made at authorized Ferri workshops
	Forward speed excessive for the type of work being performed	Reduce forward speed
Arm lowered involuntarily	Excessive oil leakage from the hydraulic ram; oil seals worn-out inside the hydraulic ram	Check the hydraulic ram oil seals and sealing in general and have repairs or replacements made at authorized Ferri workshops
Excessive stiffness of the arm during work	Improper adjustment of the max. pressure valve setting	Have valve pressure setting calibrated by an authorized Ferri workshop
Belts overheating	Belt slippage. Excessive belt tension	Check the pre-tension of the belts
	Working speed not suitable to the quantity of material to shred	Reduce working speed
	Flails touching the ground	Adjust cutting height

PROBLEMS	PROBABLE CAUSE	REMEDIES
Leakage of oil from motor	Motor gasket damaged	Replace motor gasket
		Check the condition of the discharge filter and replace if necessary
	Oil leakage onto the motor	Check the condition of the joints, seals, and hoses (especially for drainage). Replace if they are clogged or damaged
Excessive pump noise	Pump worn or damaged	Repair or replace the pump at authorized Ferri workshops. Check the condition of the discharge filter and replace if necessary
	Wrong type of oil in the hydraulic system	Check the condition of the oil in the tank and change if necessary
Excess motor noise	Motor worn or damaged	Repair or replace the motor at authorized Ferri workshops. Check the condition of the discharge filter and replace if necessary
	Wrong type of oil in the hydraulic system	Check the condition of the oil in the tank and change if necessary
Difficulty in sliding the PTO shaft out of its housing	PTO shaft not lubricated	Lubricate the PTO shaft
	Bent PTO	Replace the PTO
Excessive slack in arm pins	Worn pins	Replace the pins
	Worn bushes	Replace bushes
Excessive noise from the arm hinges	Insufficient lubrication due to clogging of the lubrication duct	Check the condition of the grease nipple, clean and replace if damaged. Check for clogging in the lubrication duct

PROBLEMS	PROBABLE CAUSE	REMEDIES
Irregular arm operation	Maneuver speed not suitable	Adjust the number of tractor PTO rpm
		Adjust the maneuvering speed for the function affected, using the adjustable choke (if any). Otherwise, take it to an authorized workshop
	Air in the hydraulic circuit	Bleed the air from inside the circuit
Flail head rotor fails to start	Limited hydraulic capacity	Check motor operation. Repair or replace motor
		Check the hydraulic hoses affected for damage or clogging. Repair or replace the hydraulic hoses
		Make sure that the discharge filter or delivery filter (if any) is not clogged. If necessary, replace it.
	Check the flexible wire for remote control of the rotor distributor. Adjust the remote control wire	
	Mechanical transmission missing	Check bevel gear pair box operation. Repair or replace
Leakage of oil from the pump	Oil leaking from the pump	Check the condition of the joints, seals, and hoses (especially for drainage). Replace if they are clogged or damaged
Premature belt breakage	Belt tension too high	Check the pre-tension of the belts
	Pulleys out of alignment	Align the belts
	Flails touch the ground	Adjust height of cut
	Tractor has more power than the machine can withstand	Connect the machine to a tractor with adequate power
Belts slipping on the pulleys	Insufficient belt tension	Check the pre-tension of the belts

09-TROUBLESHOOTING (Generate)

10 DEMOLITION AND DISPOSAL

If the machine is to be scrapped, it must be disposed of in a suitable waste disposal site, complying with the legislation in force.

In case of demolition, all potentially hazardous parts of the machine must be rendered innocuous.

Recover any old oil and dispose of it at the special oil disposal centers.

Before scrapping the machine, separate plastic or rubber parts, electric and electronic material.

The materials used in the machine that have to be disposed of separately are:

- ▶ Steel
- ▶ Mineral oil
- ▶ Rubber
- ▶ Plastic
- ▶ Electrical system wires

Parts consisting entirely of plastic, aluminum and steel can be recycled at special differentiated waste collection centers.



WARNING

Do not dispose of the used oil carelessly. Oil is a special waste and must be delivered to specific collection centers, in accordance with the laws in force.

Page left blank intentionally

11 WARRANTY

When the machine is delivered, check that the machine and its separate accessories have not been damaged in shipment and handling.

Any claims must be sent in writing to FERRI within eight days of receipt of the machine, enclosing a copy of the delivery documents countersigned by the person in charge of transport or handling.

The buyer may claim the rights relative to the warranty if he has:

- ▶ Complied with the clauses in the supply contract;
- ▶ Complied with the general guarantee conditions, indicated on the coupon "General Guarantee Conditions", filling in all the parts and signing the DELIVERY CERTIFICATE.

For the replacement of parts, use only original replacements furnished by the Manufacturer or authorized dealerships. When ordering spare parts, specify the data listed on the machine identification plate, in particular:

- 1) Series
- 2) Year of manufacture
- 3) Serial number

FERRI ensures the spare parts for a minimum period of **10 years from the end of production of the series.**

11-GARANZIA



Product Registration Card

To register your new FERRI Boom Mower, In-Line/Slope Mower or Flail Mower completely fill out the card below and mail it back to FERRI (Postage is already paid)

Warranty Proof: *Your registration serves as proof of purchase for your warranty coverage. Please make sure the card is completed in order to guarantee coverage.*

Date _____ **Please Print Information**

Owner Information		Dealer Information
First Name _____	Last Name _____	Dealer Name _____
Company Name _____		Address _____
Address _____		City, State, Zip _____
City, State, Zip _____		Dealer Signature _____
Telephone # _____	Fax # _____	Dealer Phone # _____
Owner Signature _____		

Model Purchased _____	Product to be used for:
Serial Number _____	<input type="checkbox"/> Government Agency <input type="checkbox"/> Municipality
Date Purchased _____	<input type="checkbox"/> Golf Course <input type="checkbox"/> Agricultural
Accessories Purchased _____	<input type="checkbox"/> School <input type="checkbox"/> Landscaping
_____	<input type="checkbox"/> Other _____

11.1

11.1 Invalidation of the Warranty

THE WARRANTY IS NO LONGER VALID WHEN:

- ▶ The fault is due to errors in handling;
- ▶ Routine maintenance has not been carried out;
- ▶ Routine maintenance has been carried out in technically improper ways;
- ▶ Routine maintenance has been carried out by unqualified personnel;
- ▶ The power limit of the machine has been exceeded;
- ▶ **Spare parts are used that are not original and in any case not supplied or authorized by FERRI;**
- ▶ The instructions in this manual have not been followed.

Page left blank intentionally

11-GARANZIA

12 OPTIONAL UNITS



Wear safety footwear, overalls, safety gloves and, if necessary, earplugs and a face mask during operations of maintenance, repair, movement or storage of the machine.



Before you perform any type of maintenance:

- 1) Wait until all moving parts have come to a complete stop;**
- 2) Lower the machine to the ground;**
- 3) Disconnect the power take-off;**
- 4) Switch off the tractor engine (or vehicle);**
- 5) Apply the parking brake;**
- 6) Remove the ignition key;**
- 7) Get off the tractor to check the extent of the problem;**
- 8) Wait for the oil and hot surfaces to cool;**
- 9) Proceed with any repairs required on the machine.**

12.1 Controls with distributor

For tractors with only one oil intake, or at specific customer request, it is possible to fit a control distributor for the hydraulic rams, also equipped with a floating position for controlling the orientation of the shredder.

12.1.1 Assembly procedure

- 1) Screw or weld the plate (1) on the three-point connector in the position shown.

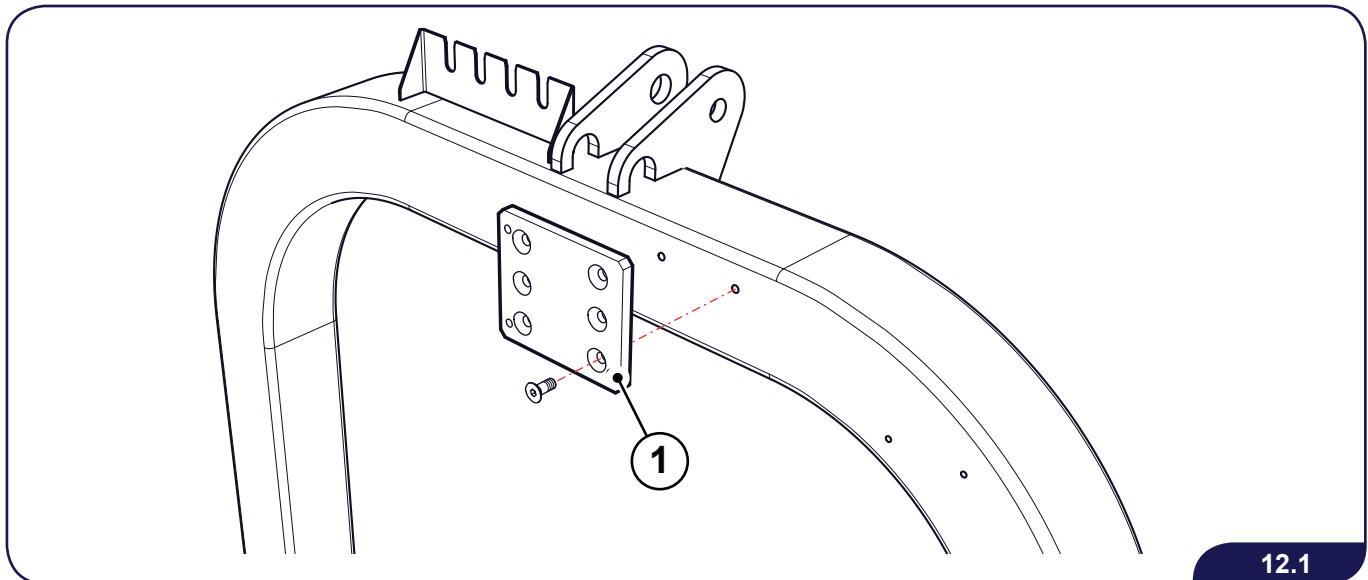

12.1

- 2) Fit the distributor (2), fastening it to the plate (1) with the relative screws (3).

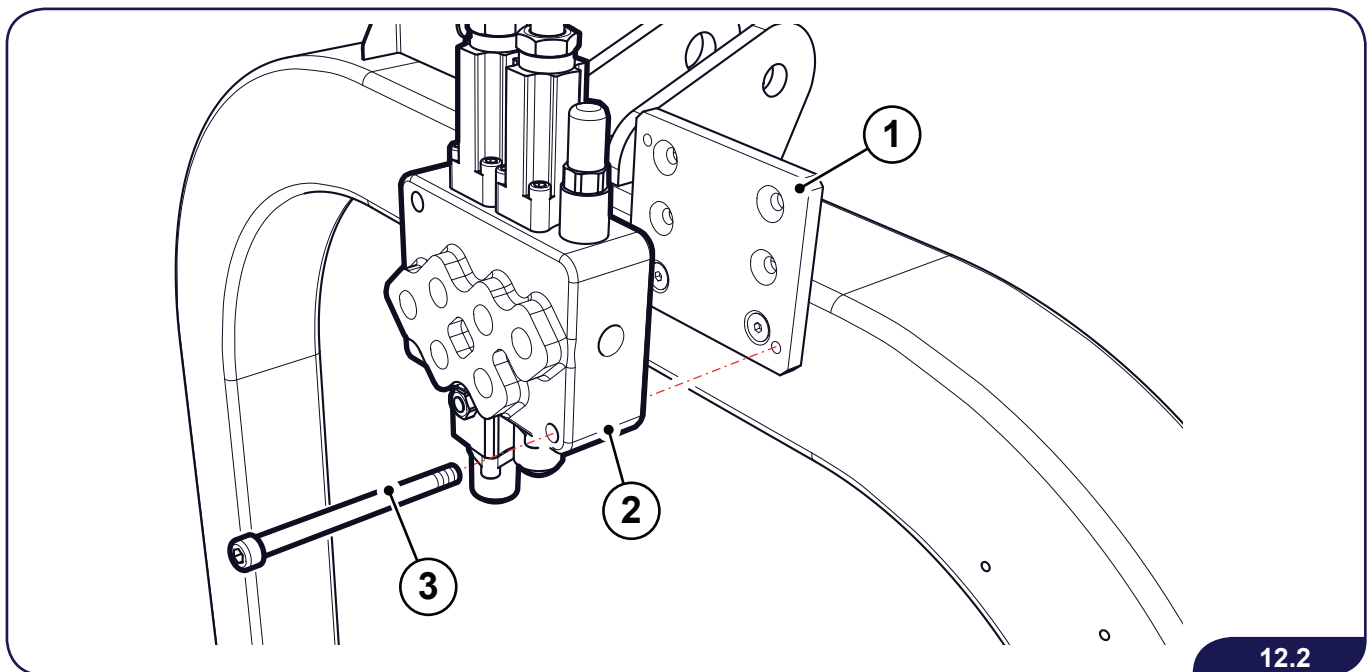

12.2

- 3) Screw the reduction coupling (5) in place with its sealing washers. Remove the four snap connectors (4) from the hoses and install two on the supply hoses (6).



CAUTION

Put the two unused snap couplings away in a safe place.

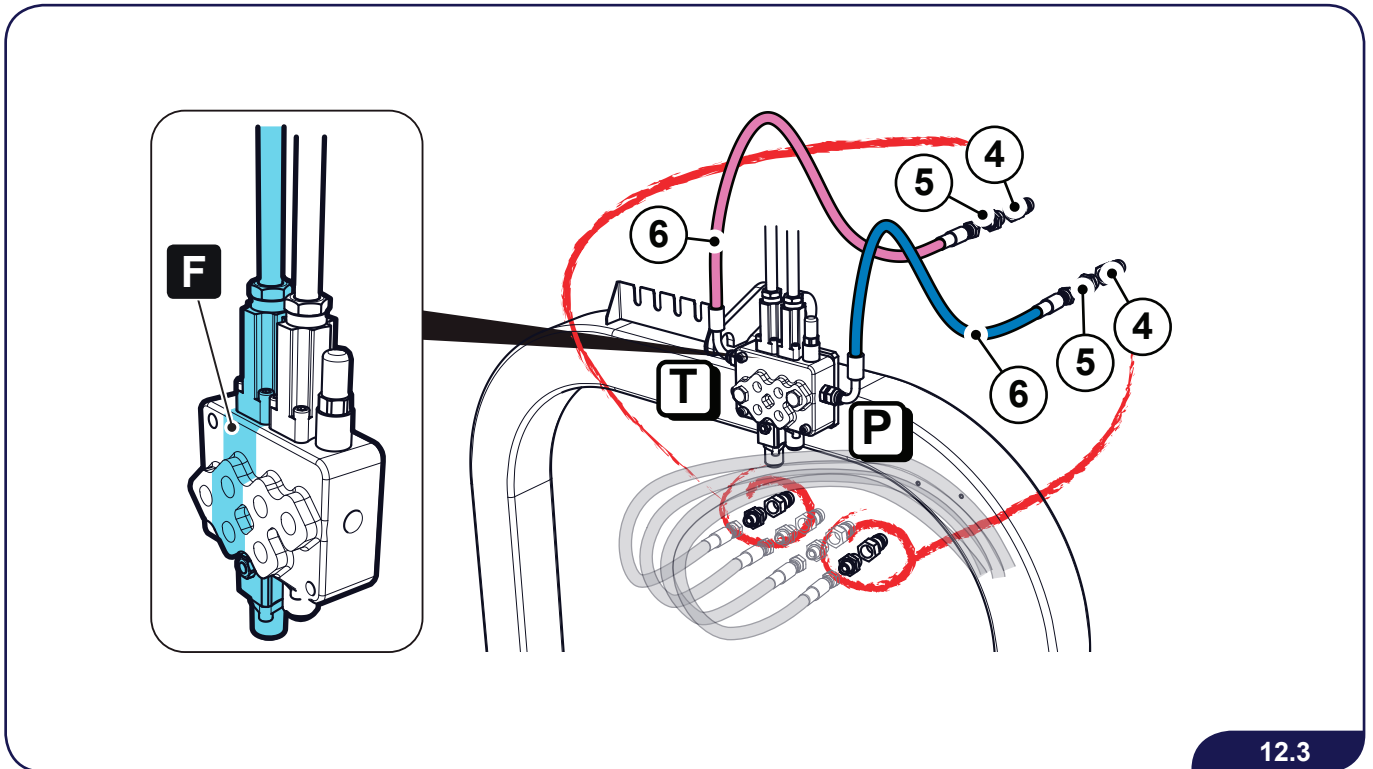

12-Comandi con distributore (ZT-ZTE)

12.3

- 4) Fasten the four reduction couplings to the distributor with their sealing washers. Connect the hoses (7) to the distributor as shown in the figure.

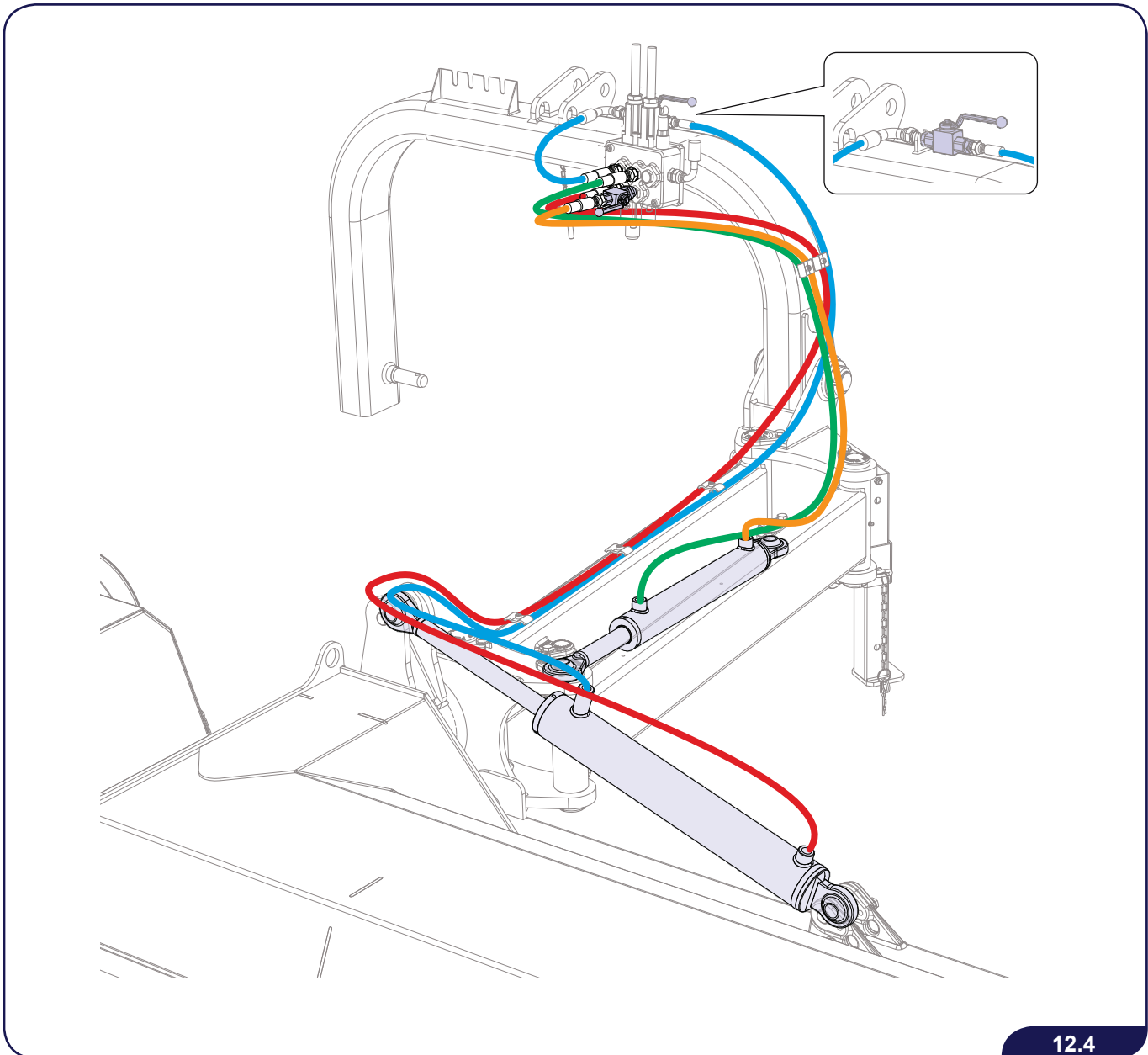

12-Comandi con distributore (ZT-ZTE)

12.4



The floating element (F) must be connected to the hydraulic ram for orientation of the shredder (1) (see Chapter 6).

12.2 Adjustable lateral runners

Application of the runners (1) serves to prevent premature wear of the flails.

The runners are fastened to the side walls of the shredder with screws (2), washers (3) and nuts (4), and are positioned as shown in the figure.

The height adjustment must be made at the same time as on the supporting roller (see Chapter 5).

12-Slitte laterali regolabili (ZT-ZTE)

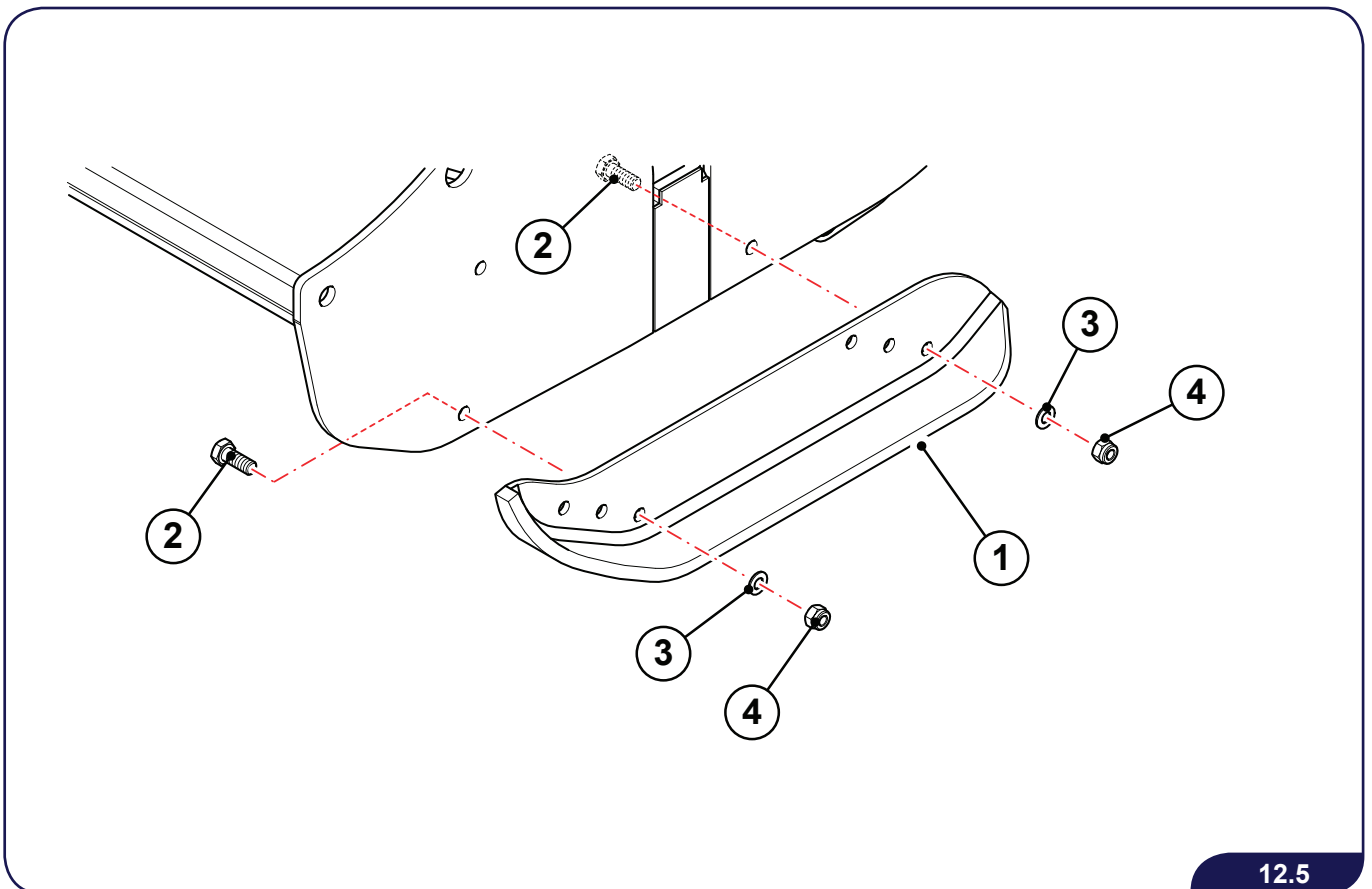

Page left blank intentionally

12-Slitte laterali regolabili (ZT-ZTE)



FERRI[®]

FERRI s.r.l.

Via C. Govoni, 30
Tel/Phone: 39-0532.866866
<http://www.ferrisrl.it>

44030 Tamara (FE) - ITALY
Fax: +39-0532.866851
e-mail: info@ferrisrl.it

FERRI[®]

Spare Parts & Customer Service at:

J.S. Woodhouse Co.
Inc. 1314 Union Street
Tél. 413-736-5462
<http://www.ferri-america.com>

P.O. Box 1169
West Springfield, Ma. 01090 U.S.A.
Fax. 413-732-3786
e-mail: info@JSWoodhouse.com